

# ADM-Aeolus Level-2B/2C Processor Input/Output Data Definitions Interface Control Document

## Authors

**Jos de Kloe**, Ad Stoffelen  
KNMI

David Tan, Erik Andersson, Michael Rennie  
ECMWF

Alain Dabas, Paul Poli  
MÉTÉO-FRANCE

Dorit Huber  
DLR

issue number: 2.0  
issue date: 7-Dec-2012

## Change log

Table 1: List of changes describing the history of this document.

Version	Date	Comment
1.0 (draft)	17-Feb-2006	First draft
1.0	05-May-2006	ESA comments on first draft.
1.1 (draft)	16-Jun-2006	Correction of typographical errors in L2B Sections. Draft of L2C supplementary datasets.
1.1	21-Aug-2006	Inclusion of AUX_CLM definition. L2B updates: <ul style="list-style-type: none"> <li>• Moved L1B filename to auxiliary reference datasets</li> <li>• More L1B statistics in L2B SPH &amp; DSD re-ordering</li> <li>• Re-define normalization of measurement weights</li> </ul> Aux_Par_2B updates: <ul style="list-style-type: none"> <li>• Additional parameters</li> </ul>
1.2	11-Dec-2006	L2BC SPH: edits for L2C-specific parameters. Aux_Par_2B: modified matchup parameters. Addition of Header root tags (XML format only.) Editorials (including points from GSDR RID 166).
1.3	23-Feb-2007	Add DSD for AUX_CAL data. Re-ordering of DSDs in L2C files (SPR ADM-L2BP-0002). Spare fields reserved for a 36-character Obs_Type.String. Add Rangebin_Mismatch_Tolerance to AUX_PAR_2B. Editorials.
1.31	15-Jun-2007	SPR ADM-L2BP-0008 (ACMF-24): Explain that XML sizes are indicative only. SPR ADM-L2BP-0014 (ACMF-61): FileTypes AUX_CLM.L2 and AUX_RBC.L2. SPR ADM-L2BP-0018 (ACMF-65): Typo Proc_Center in AUX_PAR_2B. SPR ADM-L2BP-0019 (ACMF-66): Specify unit for extinction_threshold in AUX_PAR_2B. SPR ADM-L2BP-0021 (ACMF-68): Unit km for Max_Allowed_Distance in AMD_Matchup_Params. Remove obsolete RBC tables - superseded by separate reference document. Remove references to FileType ALD_U_T_2Z - now phased out.
1.32	16-Jan-2008	AUX_PAR_2B: make units for Mie_Core_Algorithm_Params more consistent with AUX_PAR_1B. AUX_CLM.L2, AUX_PAR_2B, AUX_PAR_2C: minor editorials. Removal of "Under Review" comments related to File_Type ALD_U_N_2B (GSDR RID 166). SPRs ADM-L2BP-0006/0023 (ACMF-22): Addition in XML-HDR files of microseconds to DateTime fields outside FixedHeader.

Continued on Next Page...

Version	Date	Comment
1.40 (draft A)	30-Nov-2008	Clarifications for Missing Data Indicators. Options for ESA to consider for System field in FH. IntAus for Abs_Orbit field in MPH. Two typos in AUX_CLM description as noted by Mathieu Olivier. Typos where “clear” and “cloudy” were interchanged in Obs_Type fields. Remove specification of internal representation of enumerated-type processing parameters. AUX_PAR_2B updates: remove Spares, add new ZWC_Params.
1.40 (non-draft)	28-Feb-2009	Update version numbers of Reference Documents. Uppercase/lowercase typos in Aux_Par_2B/2C.
1.50 (draft A)	29-Jun-2010	Table 2: Further clarifications for GSDR RID 166 and ARTS AE-IPF-41 (Action 113). Editorials (p13, AUX_MET_EC -i, AUX_MET_12). Update of AUX_PAR_2B format (Section 5.4). Update of Level-2B/2C product format (Section 4).
1.50	11-Apr-2011	Spelling corrections, updated references and comments next to obsolete variables in AUX_PAR_2B (Section 5.4)
2.00	1-May-2012 upto 14-Nov-2012	completely redesigned fileformat to adapt to the new Continuous Mode processing

- end of table -

# Contents

<b>Table of contents</b>	<b>4</b>
<b>List of figures</b>	<b>6</b>
<b>List of tables</b>	<b>7</b>
<b>1 Introduction</b>	<b>10</b>
1.1 Purpose of Document	10
1.2 Format Definition Relation	10
1.3 Relationship of the Input/Output Data Definition Files	11
<b>2 Documents and acronyms</b>	<b>14</b>
2.1 Applicable documents	14
2.2 Reference documents	14
2.3 Acronyms	15
<b>3 General Input/Output File Format</b>	<b>16</b>
3.1 File Naming Conventions	16
3.2 Format Conventions (XML, KVT, Binary)	17
3.2.1 Usage of Spare fields	17
3.3 Specific Field Details	17
3.3.1 Quality Flags	17
3.3.2 Longitude/Latitude	21
3.4 General File Structure	21
3.4.1 Fixed Header	21
3.4.2 Main Product Header	24
3.4.3 Data Set Descriptor Content Description	26
3.5 L2B/L2C/AMD Conventions for Missing Data Indicators	26
<b>4 Level 2B/2C Product</b>	<b>27</b>
4.1 Product Structure	27
4.1.1 File Name	27
4.1.2 File Structure	27
4.2 Specific Product Header	27
4.2.1 Data Set Descriptors	31
4.3 Data Sets	32
4.3.1 Measurement Map ADS	33
4.3.2 Mie and Rayleigh Grouping ADS	33
4.3.3 Geolocation ADS	34
4.3.4 L2B AMD Product Confidence Data (PCD) ADS	36
4.3.5 L2B Meas Product Confidence Data (PCD) ADS	37
4.3.6 L2B/L2C Mie Wind Product Confidence Data ADS	47
4.3.7 L2B/L2C Rayleigh Wind Product Confidence Data ADS	49
4.3.8 Mie HLOS wind Profiles MDS	51
4.3.9 Rayleigh HLOS wind Profiles MDS	52
4.3.10 L2B Wind Profile MDS	54
4.3.11 L2C Mie Assimilation Product Confidence Data (PCD) ADS	55
4.3.12 L2C Rayleigh Assimilation Product Confidence Data (PCD) ADS	57
4.3.13 Mie Vector-Wind Profiles MDS	59
4.3.14 Rayleigh Vector-Wind Profiles MDS	60
4.4 File Size	60

<b>5</b>	<b>Input Auxiliary Files</b>	<b>65</b>
5.1	Auxiliary Meteorological Data Set	65
5.1.1	Product Structure	65
5.1.2	File Name	65
5.1.3	File Structure	66
5.1.4	Specific Product Header	66
5.1.5	Data Set Descriptors	67
5.1.6	Data Sets	67
5.1.7	GEOLOCATION ADS	68
5.1.8	METEOROLOGICAL MDS	68
5.1.9	File Size	69
5.2	Rayleigh-Brillouin Correction (RBC) tables	70
5.3	Auxiliary Climatology Dataset	70
5.3.1	Product Structure	71
5.3.2	File Name	71
5.3.3	File Structure	71
5.3.4	Clim Specific Product Header	71
5.3.5	DATA SET DESCRIPTORS	72
5.3.6	Clim Data Set	72
5.3.7	File Size	73
5.4	Level-2B Processing Parameters and Algorithm Settings	74
5.4.1	Product Structure and Size	74
5.4.2	File Name	74
5.4.3	File Structure	75
5.4.4	Specific Product Header	75
5.4.5	Data Set Descriptor	75
5.4.6	Level 2B Processing Parameters GADS	75
5.5	Files supplied to the L2-PF and National Weather Services	94
5.6	Level-2C Processing Parameters and Algorithm Settings	94
5.6.1	Product Structure and Size	95
5.6.2	File Name	95
5.6.3	File Structure	95
5.6.4	Specific Product Header	95
5.6.5	Data Set Descriptor	96
5.6.6	Level 2C Processing Parameters GADS	96
5.7	Auxiliary Calibration Coefficients Dataset	98

---

## List of Figures

1	<i>Relationship of Input/Output Files for the Aeolus Level-2B Processor</i> . . . . .	11
2	Example of L2B/L2C Fixed Header. . . . .	23

## List of Tables

1	List of changes describing the history of this document.	2
2	Format Definition Table	10
3	List of Level-2B Input/Output Data Definition Files	11
4	Supporting files defined in other documents	12
5	Format conventions used for headers in XML format	18
6	Format conventions used for headers in KVT format	19
7	Data types and corresponding size in bytes for binary data	20
8	L2B/L2C Fixed Header Content Description	21
9	L2B/L2C Fixed Header Validity_Period Content Description	22
10	L2B/L2C Fixed Header Source Content Description	22
11	L2B/L2C Main Product Header Content Description	24
12	L2B/L2C Data Set Descriptor Content Description	26
13	L2B/L2C Specific Product Header Content Description	28
14	Level-2B/2C Data Sets	31
15	L2B/L2C Measurement Map ADS Content Description	33
16	Meas_Map Content Description	33
17	Meas_Map_Bin Content Description	33
18	Grouping ADS Content Description	34
19	Reasons to end grouping	34
20	L2B/L2C Geolocation ADS Content Description	35
21	WindResult_Geolocation Content Description	35
22	L2B AMD Product Confidence Data ADS Content Description	36
23	L2B_AMD_Screening Content Description	36
24	Valid values for the L2B_AMD_Screening_QC field of the L2B_AMD_Screening structure	37
25	L2B Measurement Product Confidence Data ADSR Content Description	37
26	L2B/L2C AMD Collocation Content Description	38
27	Valid values for the matchup_QC field of the L2B/L2C_AMD_Collocation structure	38
28	L2B/L2C Product Confidence Data L1B_Input_Screening Content Description	39
29	L2B/L2C PCD L1B Observation Screening Content Description	39
30	Valid values for the Obs_Screening field of the L2B/L2C PCD L1B_Input_Screening structure.	39
31	L2B/L2C Product Confidence Data L1B Mie_Meas screening Content Description	41
32	Valid values for the L1B_Mie_Meas_QC field of the L2B/L2C Product Confidence Data L1B Mie_Meas Screening structure	41
33	L2B/L2C Product Confidence Data L1B Mie_Meas_Bin screening Content Description	42
34	Valid values for the L1B_Mie_Meas_Bin_QC field of the L1B Mie_Meas_Bin Screening structure	42
35	L2B/L2C Product Confidence Data L1B Rayleigh_Meas screening Content Description	42
36	Valid values for the L1B_Rayleigh_Meas_QC field of the L1B Rayleigh_Meas Screening structure	43
37	L2B/L2C Product Confidence Data L1B Rayleigh_Meas_Bin screening Content Description	43
38	Valid values for the L1B_Rayleigh_Meas_Bin_QC field of the L1B Rayleigh_Meas_Bin Screening structure	44
39	L2B/L2C Product Confidence Data L2B_Mie_Meas_Classification_QC Content Description	44
40	L2B/L2C Product Confidence Data L2B_Mie_Meas_Bin_Classification_QC Content Description	45
41	Valid values for the Applied_ScatRatio_Method field of the L2B_Mie_Meas_Bin_Classification_QC structure (compare also the strings used by the L2B AuxPar file, see table 101)	45
42	L2B/L2C Product Confidence Data L2B_Rayleigh_Meas_Classification_QC Content Description	46
43	L2B/L2C Product Confidence Data L2B_Rayleigh_Meas_Bin_Classification_QC Content Description	46
44	L2B/L2C Mie Wind Product Confidence Data L2B_Mie_Processing_QC ADS Content Description	47
45	Mie channel wind retrieval output QC parameters	47
46	L2B/L2C Rayleigh Wind Product Confidence Data L2B_Rayleigh_Processing_QC ADS Content Description	49
47	Rayleigh channel wind retrieval output QC parameters	49

48	Valid values for the extinction_method field of the L2B_Rayleigh_Wind_QC L2B/L2C Product Confidence Data L2B_ObsRayleigh_Bin_QC structure . . . . .	51
49	Valid values for the Scattering_Ratio_method field of the L2B_Rayleigh_Wind_QC L2B/L2C Product Confidence Data L2B_ObsRayleigh_Bin_QC structure . . . . .	51
50	L2B/L2C Mie HLOSwind Data Set MDSR Content Description . . . . .	51
51	L2B/L2C Mie HLOSwind Data List_of_Mie_Height_Bin_Winds Result Content Description . . . . .	52
52	Valid values for the observation_type field . . . . .	52
53	L2B/L2C Rayleigh HLOSwind Data Set MDSR Content Description . . . . .	52
54	L2B/L2C Rayleigh HLOSwind result Data List_of_Rayleigh_Height_Bin_Winds Content Description . . . . .	53
55	L2B/L2C Wind Profile MDS Content Description . . . . .	54
56	L2B Wind Profile Content Description . . . . .	54
57	Valid values for the Channel field . . . . .	55
58	L2C Mie Assimilation Product Confidence Data ADSR Content Description . . . . .	55
59	L2C Assimilation Product Confidence Data List_of_ L2C_Mie_Quality_Params Content Description . . . . .	55
60	L2C Mie Height Bin Quality Params Content Description . . . . .	56
61	L2C Mie Assimilation Product Confidence Data L2B_Mie_Obs_Screening Content Description . . . . .	56
62	Valid values for the L2B_Mie_Obs_QC field of the L2C Product Confidence Data L2B_Mie_Obs_Screening structure . . . . .	56
63	L2C Assimilation Product Confidence Data L2C_Assimilation_Model_PCD Content Description . . . . .	57
64	L2C Assimilation Product Confidence Data HLOS_Observation_Errors Content Description . . . . .	57
65	L2C Rayleigh Assimilation Product Confidence Data ADSR Content Description . . . . .	57
66	L2C Assimilation Product Confidence Data List_of_ L2C_Rayleigh_Quality_Params Content Description . . . . .	58
67	L2C Rayleigh Height Bin Quality Params Content Description . . . . .	58
68	L2C Rayleigh Assimilation Product Confidence Data L2B_Rayleigh_Obs_Screening Content Description . . . . .	58
69	Valid values for the L2B_Rayleigh_Obs_QC field of the L2C Product Confidence Data L2B_Rayleigh_Obs_Screening structure . . . . .	59
70	L2C Mie Vector-Wind Data Set MDSR Content Description . . . . .	59
71	L2C Mie Vector-Wind Bin Data List_of_Mie_Height_Bin_VecWinds and Rayleigh Wind Data List_of_Rayleigh_Height_Bin_VecWinds Content Description . . . . .	59
72	L2C Rayleigh Vector-Wind Data Set MDSR Content Description . . . . .	60
73	Total sizes of the L2B/L2C product DataBlock components . . . . .	60
74	Overall organization of L2B output and input products. The attached datasets are L2B output, referenced datasets are L2B input. Daily sizes in the last column based on 16 orbits / day. . . . .	61
75	L2B Auxiliary Meteorological Data Specific Product Header Content Description . . . . .	66
76	Auxiliary Meteorological Data Sets . . . . .	67
77	L2B Auxiliary Meteorological Data Geolocation Data Set #1 and #2 ADSR Content Description. Note that AMD_zg shall be removed following confirmation that geoid height will be supplied in L1B data. . . . .	68
78	L2B Auxiliary Meteorological Data Meteorological Set #1 and #2 MDSR Content Description . . . . .	68
79	L2B Auxiliary Meteorological Data List_of_Profile_Data Content Description . . . . .	69
80	Size of L2B Auxiliary Meteorological Data file. One file is produced every time an assimilation is run, that is, every 12 hours. . . . .	70
81	Aux Clim Specific Product Header Content Descriptor . . . . .	71
82	Climatology Data Set Content Description . . . . .	72
83	ClimLatLonAlt Data Set Content Description . . . . .	72
84	ClimLonAlt Data Set Content Description . . . . .	73
85	ClimAlt Data Set Content Description . . . . .	73
86	ClimData Data Set Content Description . . . . .	73
87	Size of Aux Clim file. . . . .	74
88	Structure and Size of the L2B Processing Parameters file. . . . .	74



89	Structure and content of the Specific Product Header of the AUX_PAR_2B file	75
90	Level 2B Processing Parameters GADS Content Description	75
91	FH_Default_Fields Content Description	76
92	MPH_Default_Fields Content Description	76
93	WVM_Params Content Description	76
94	Grouping parameters content description	77
95	Possible Grouping methods	78
96	Classification_Params Content Description	78
97	Valid values for the Classification Type fields of the L2B AuxPar Classification Params structure	79
98	BackscatterRatio_Threshold content description	79
99	Extinction_Threshold content description	79
100	Optical_Properties_Params Content Description	80
101	Valid methods for determining backscatter ratio (Backscatter ratio method and IntAuc value for L2B PCD ADS) (compare also the values used by the L2B Measurement PCD, see table 41)	80
102	Valid methods for determining particle extinction	80
103	Valid methods for determining molecular extinction	81
104	Error_Quantifier_Params Content Description	81
105	Valid methods for determining Error Quantifier for the Mie channel	81
106	Valid methods for determining Error Quantifier for the Rayleigh channel	81
107	Common_Processing_Params Content Description	82
108	Mie_PCD_Params Content Description	82
109	Mie_Core_Algorithm_Params_Content Description	82
110	Corrupt_Data_Detection_Params_Content Description	83
111	Mie_Algorithm_Params Content Description	83
112	Valid methods for Mie height assignment	84
113	SNR_Threshold content description	84
114	Valid methods for Altitude_Reference	84
115	RBC_Algorithm_Params Content Description	84
116	Valid methods for Rayleigh height assignment	85
117	AMD_Matchup_Params Content Description	85
118	Valid values for AMD_Matchup_Params parameter Matchup_Method	85
119	CLM_Matchup_Params Content Description	85
120	Valid values for CLM_Matchup_Params parameter Matchup_Method	86
121	ZWC_Params Content Description	86
122	Valid values for ZWC_Params parameters ZWC_Scheme_Mie and ZWC_Scheme_Rayleigh	86
123	Screening_Params Content Description	87
124	L1B_Screening_Params Content Description	87
125	L1B_Geolocation_Screening_Params Content Description	87
126	L1B_Obs_Screening_Params Content Description	88
127	L1B_Mie_Meas_Screening_Params Content Description	89
128	L1B_Rayleigh_Meas_Screening_Params Content Description	91
129	L1B_Cal_Char_Data_Screening_Params Content Description	92
130	L1B_Sat_Char_Data_Screening_Params Content Description	92
131	L1B_Mie_Resp_Calib_Data_Screening_Params Content Description	92
132	L1B_GWD_ADS_Screening_Params Content Description	93
133	L2B_AMD_Screening_Params Content Description	94
134	Structure and Size of the L2B Processing Parameters file.	95
135	Structure and content of the Specific Product Header of the AUX_PAR_2C file	96
136	Level 2C Processing Parameters GADS Content Description	96
137	L2C_Assim_Params Content Description	96
138	L2C_Screening_Params Content Description	97
139	L2B Input_Screening_Params Content Description	97
140	L2B Mie_Obs_Screening_Params Content Description	97
141	L2B Rayleigh_Obs_Screening_Params Content Description	98

# 1 Introduction

## 1.1 Purpose of Document

This document defines the interface specification for data files that constitute the input to and output from the ADM-Aeolus Level-2B Processor (L2BP), with particular emphasis on the version to be installed in the Aeolus Ground Segment for Reprocessing purposes. The input/output files required for the L2BP and their purpose are described in [RD1]; the preliminary format definitions given therein are superseded by the current document. In general terms, the file specifications must adhere to the content and formats defined in [AD1]–[AD6].

For installations of the L2BP in an operational numerical weather prediction environment, e.g. a national weather service or ECMWF, an interface specification involving the BUFR format is under development [RD2]. Any such environment may also choose to install a reference version of the L2BP adhering to the input/output data definitions contained in the current document.

This document also defines those files associated with ADM-Aeolus Level-2C processing that are relevant to the Aeolus Ground Segment (specifically the Long Term Archive). Operational L2C processing is embedded within the ECMWF forecast system and is described elsewhere [RD9]. The two L2C-related files that are described here are the L2C Output Product file and the L2C Auxiliary Processing Parameters file, both in Earth-Explorer format.

L2B product parameters are a subset of L2C product parameters and hence the strategy adopted is to define a common Earth Explorer template for L2B and L2C product files. In L2B product files, the datasets that are specific to L2C processing are not defined (no DSD in the SPH). In addition, some SPH parameters that are specific to L2C processing are excluded from the definition of the L2B SPH.

## 1.2 Format Definition Relation

Table 2 below gives an overview over the format version of the different product types, where:

- **File Type** denotes the specific sub-string of the product name that identifies the product.
- **Format Version** denotes the product format version that is also used to identify the proper xmlns version.
- **REF\_DOC** denotes the document reference and the version of the IODD that introduces that specific format version of a file. The value displayed in this column will be provided in the corresponding REF\_Doc fields of the binary .DBL files, the XML .HDR files, and the XML .EEF files.
- **Modified** is a field used to specify if a certain product has been modified with the current document version
- **Processor version** denotes the software version at which the specific format version is introduced

Table 2: Format Definition Table

File Type	Format Version	Ref.Doc	Modified	Processor Version
ALD_U_N_2B	02.00	AE_IF_ECMWF_L2BP_001_*_IODD_Iss2.00	Y	02.00
ALD_U_N_2C	02.00	AE_IF_ECMWF_L2BP_001_*_IODD_Iss2.00	Y	02.00
AUX_MET_12	01.50	AE_IF_ECMWF_L2BP_001_*_IODD_Iss2.00	N	02.00
AUX_RBC_L2	02.00	AE_TN_MFG_GS_0003_20120130_IODD_Iss2.0	Y	02.00
AUX_CLM_L2	01.50	AE_IF_ECMWF_L2BP_001_*_IODD_Iss2.00	N	02.00
AUX_CAL_L2	02.05	AE_IF_MFG_L2A_004_20120512_IODD_Iss1.00	N	02.00
AUX_PAR_2B	02.00	AE_IF_ECMWF_L2BP_001_*_IODD_Iss2.00	Y	02.00
AUX_PAR_2C	02.00	AE_IF_ECMWF_L2BP_001_*_IODD_Iss2.00	N	02.00

- end of table -

Table 3: List of Level-2B Input/Output Data Definition Files

File Type Identifier	File Type	Description	Created By	Used By
	<b>Level 2B Product File</b>			
ALD_U_N_2B	Level 2B Product File	Section 4	Level 2B Processor	
	<b>Input Auxiliary Files</b>			
AUX_MET_12	Auxiliary Meteorological Data (AMD)	Section 5.1	L2-PF, access via LTA	Level 2B and 2A Processors
AUX_RBC_L2	Rayleigh-Brillouin Correction (RBC) lookup table	Section 5.2	ACMF	Level 2B Processor
AUX_CLM_L2	Climatology lookup table	Section 5.3	External provider	Level 2B and 2A Processors
AUX_CAL_L2	Calibration coefficients	Section ...	ACMF	Level 2A and 2B Processors
AUX_PAR_2B	Level 2B Processing Parameters	Section ...	ACMF and/or L2-PF (ECMWF)	Level 2B Processor

### 1.3 Relationship of the Input/Output Data Definition Files

The relationship and normal processor flow between the seven files involved in Level-2B Processor software tasks is illustrated in Figure 1. The current document gives the Input/Output Data Definition for five of them (shaded blue) as listed in Table 3. The remaining two files (shaded yellow) are defined elsewhere, see Table 4.

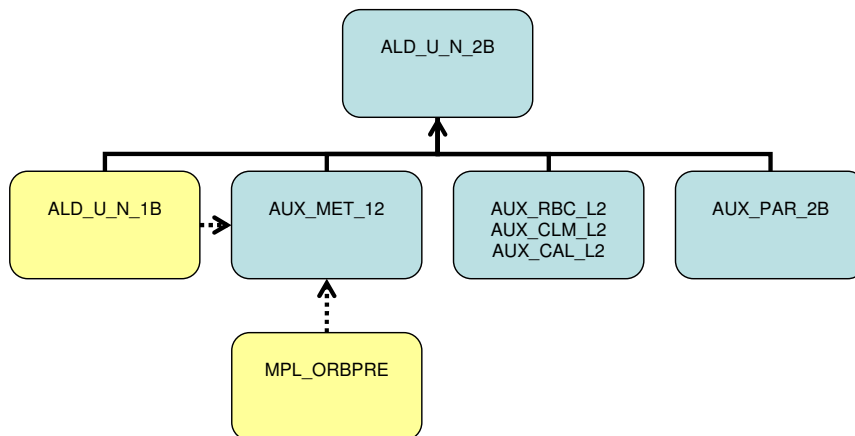

Figure 1: Relationship of Input/Output Files for the Aeolus Level-2B Processor

- The L2B file is the principal output created by the ADM-Aeolus L2B Processing task. There is only one mode (Wind Component Mode) that applies in any installation of the L2BP.
- The L1B file is the principal instrumental input to the L2B Processor and is typically provided by the Thin Layer. Two formats are envisaged:
  - EE-TGZ-format: The content of the L1B file and its EE-format definition is contained in [RD3] but is subject to modifications defined in [RD4]. The L1B data provided to the reprocessing

Table 4: Supporting files defined in other documents

File Type Identifier	File Type	Description	Created By	Used By
	<b>Level 1B Product Files</b>			
ALD_U_N_1B (.TGZ containing EE format)	Level-1B Files in Earth Explorer-TGZ format (tar, gzipped) containing 1) HDR in XML format and 2) DBL in native Earth-Explorer format). For further explanation see the text of the current section below this table.	[RD3], [RD4]	Core PDS	"Standalone" Level-2B processor, e.g. the one installed for Reprocessing
ALD_U_N_1B (.TGZ containing BUFR format)	Level-1B Files in BUFR-TGZ format (tar, gzipped) containing 1) HDR in XML format and 2) DBL converted into Bufr format	[RD2]	L1B_EE2BUFR convertor	L2-PF (ECMWF), national weather services
	<b>Meteorological Support Files</b>			
MPL_ORBPRES	Predicted Orbit Files	[RD6]	FOS	L2-PF

installation of the L2BP will be in EE-format. EE-format files may nonetheless be delivered with TGZ applied (i.e. tar, g-zipped.)

- BUFR-TGZ-format: The L1B data made available to the L2-PF (ECMWF) and national weather services will be a TGZ (tar, g-zipped) file containing 1) a HDR in XML and 2) a DBL that has first undergone conversion to BUFR format [RD2]. It should be noted that the standalone L2BP interfaces to L1B-EE format; users of the L2BP who wish to interface to L1B-Bufr format are required to implement some of their own interfacing of Bufr files to the "subroutine" interface of the L2BP.

L1B files (header and geolocation information) also form one input data stream used by the L2-PF to generate auxiliary meteorological data (AUX\_MET\_12 files).

- The AUX\_MET\_12 file is an auxiliary input to the L2BP that is created by the L2-PF and is subsequently available from the LTA. It contains meteorological information that is not available in L1B data, for use in Level-2B processing as well as in Level-2A processing. There are two independent input data streams for the generation of AUX\_MET\_12 files. The first consists of actual L1B data arriving at the L2-PF before the cut-off times of the operational schedule of the L2-PF [RD1]. The second consists of predicted orbit files (MPL\_ORBPRES, discussed below).
- The AUX\_RBC\_L2 file is an auxiliary input to the L2BP that is created by the ACMF. It must be re-computed each time an Instrument Spectral Registration (ISR) is performed [RD5]. The data in the file are used as a lookup table during L2B processing to make Rayleigh-Brillouin corrections (dependent on temperature and pressure in the sensing volume).
- The AUX\_CLM\_L2 file is potentially an auxiliary input to the L2BP that is created by an external provider. The data in the file are potentially used as a lookup table during L2B processing to process Rayleigh-only height bins. The file contents consist of climatological data of atmospheric optical properties.
- The AUX\_CAL\_L2 file is potentially an auxiliary input to the L2BP that is created by the ACMF. The data in the file are used in L2A processing, to account for Mie and Rayleigh channel cross-talk, or to retrieve atmospheric optical properties. They are potentially used for similar purposes within L2B processing. The file contents consist of instrument calibration coefficients.

- The AUX\_PAR\_2B file is an auxiliary input to the L2BP that is created by external tools (e.g. a text editor), at the discretion of the site installing the L2BP. It defines processor parameters and algorithm settings as required to define operation of the L2BP.
- As discussed above, MPL\_ORBPRES (predicted orbit) files are created by the FOS and constitute an input data stream provided to the L2-PF to facilitate the generation of AUX\_MET\_12 files. The content of this file and its EE-format definition is contained in [RD6]. MPL\_ORBPRES files will be used at the L2-PF, in combination with ESA-supplied (e.g. EE CFI library or similar source code) software, to compute predicted orbit locations at which auxiliary meteorological data should be computed. The implementation is likely to be a standalone code that executes in the early stages of the operational assimilation suite at the L2-PF. It should be noted that the provision of AUX\_MET\_12 data at predicted orbit locations is contingent on the robust performance of any pre-compiled EE-CFI software used. The current working assumption is that predicted orbit files are delivered to the L2-PF at the rate of one per day, and that each file is valid for up to 7 days.
- A modified approach could be based on replacing the MPL\_ORBPRES data stream with template L1B products in which the geolocation ADS is filled with predicted locations and other datasets are empty.) This need not be pursued at the current time.

## 2 Documents and acronyms

### 2.1 Applicable documents

#### References

- [AD1] “PDS-IPF ICD Generic Interface Guidelines”, ESA-ID-ACS-GS-0001, v2.2, Aug 2006
- [AD2] “ADM-Aeolus, Data Products Contents Guidelines”, AE-TN-ESA-SY-007, v1.B, May 2004
- [AD3] “Earth Explorer Ground Segment File Format Standard”, PE-TN-ESA-GS-0001, v1.4, Jun 2003
- [AD4] “CFI Software: Mission Conventions Document”, CS-MA-DMS-GS-0001, v1.3, Jul 2003
- [AD5] “PDS to ECMWF: Interface Control Document.”, XADM-GSEG-EOPG-ID-04-0002, v1.6, Nov/Dec 2007
- [AD6] “Implementation of Level 2B/2C Processing Facility. Technical Requirements”, XADM-GSEG-EOPG-RD-04-0003, v1.1, Jun 2004

### 2.2 Reference documents

#### References

- [RD1] “Selection of L2B Parameters (Study TN2.1)”, AE-TN-MFG-L2P-0021, v2.0, May 2006
- [RD2] “WMO FM94 (BUFR) description of ADM-Aeolus L1B/L2B products”, AE-TN-ECMWF-L2P-0072-TEMPLATE, v1.31, Apr 2011
- [RD3] “Aeolus Level 1B Processor Input/Output Data Definitions Interface Control Document”, ADM-IC-52-1666, v3.12, Dec 2010
- [RD4] “Aeolus Product Modifications for Implementation in L1bP Code V2”, AE-TN-DLR-APM-L1B-150206, v1.3, Feb 2006
- [RD5] “ILIAD Lookup Table: Detailed Processing Model”, AE-TN-MFG-GS-0001, v1.0, Oct 2005
- [RD6] “Explorer\_Data\_Handling Software User Manual”, CS-MA-DMS-GS-0009, v3.4, Nov 2005
- [RD7] “ADM-Aeolus Level-2B Algorithm Theoretical Baseline Document (Mathematical Description of the Aeolus Level-2B Processor)”, AE-TN-ECMWF-L2BP-0023, v2.3, Apr 2011
- [RD8] “ADM-Aeolus Rayleigh-Brillouin Correction Look-up Tables Generator: Input/Output Data Definitions Interface Control Document”, AE-TN-MFG-GS-0003, v1.2, Jun 2007
- [RD9] “Definition of Baseline Aeolus Level-2C Processing (Study TN6.2)”, AE-TN-ECMWF-L2BP-0062, v1.0, In preparation
- [RD10] “Aeolus Level 2a Processor Input/Output Data Definition”, AE-IF-DLR-L2A-004, v1.3, Jan 2007

## 2.3 Acronyms

ACMF	Aeolus Calibration and Monitoring Facility
ADS	Annotation Data Set
AMD	Auxiliary Meteorological Data
AOCS	Attitude and Orbit Control System
BRC	Basic Repeat Cycle
BUFR	Binary Universal Format for Representation
CFI	Customer Furnished Item
DBL	Data Block
DEM	Digital Elevation Map
DSD	Data Set Descriptor
DSR	Data Set Record
DS	Data Set
ECMWF	European Centre for Medium-Range Weather Forecast
EE	Earth Explorer
FH	Fixed Header
FOS	Flight Operations Segment
GADS	Global Annotation Data Set
HDR	Header
HLOS	Horizontal Line of Sight
KVT	Key, Value, Terminator
IAT	Instrument Auto Test
IODD	Input/Output Data Definition(s)
ICD	Interface Control Document
ISR	Instrument Spectral Registration
L1B	Level-1B
L2B	Level-2B
L2BP	Level-2B Processor
L2-PF	Level-2B Processing Facility (ECMWF)
LOS	Line Of Sight
LTA	Long Term Archive
MDS	Measurement Data Set
MPH	Main Product Header
MRC	Mie Response Calibration
NWP	Numerical Weather Prediction
PBL	Planetary Boundary Layer
PCD	Product Confidence Data
PDS	Payload Data Segment
PRF	Pulse Repetition Frequency
QC	Quality Control
RBC	Rayleigh Brillouin Correction
RRC	Rayleigh Response Calibration
SNR	Signal to Noise Ratio
SPH	Specific Product Header
TBD	to be defined (later)
VH	Variable Header
WGS84	World Global System 84 : Reference Ellipsoid for GPS data.
WMO	World Meteorological Organization
XML	Extensible Markup Language
TGZ	Tar, g-zipped.
ZWC	Zero Wind Correction

### 3 General Input/Output File Format

It is envisaged that all Aeolus L2B-related files handled by the Thin Layer will conform to EE-format. The general conventions for EE-format have been detailed elsewhere [AD3], [RD3] but are repeated in this Section to make the current document self-contained. The L1B files destined for transfer to the L2-PF and national weather services are regarded as the sole exception: they are expected to be in BUFR-TGZ format (Section 1.3).

#### 3.1 File Naming Conventions

The file naming conventions to be applied for Aeolus data files and products are in line with the Earth Explorer File Format Standard [AD3]. The general file name structure is:

AE\_CCCC\_TTTTTTTTTT\_<instance\_ID>.EEE

where

“AE” denotes the Aeolus mission

CCCC denotes the file class (four uppercase letters/digits)

- “OPER” for routine operations
- “RPRO” for routine re-processing
- “TEST” for internal tests
- Any other string of four uppercase letters as specified by the Order\_Type tag in the ThinLayer JobOrder file

TTTTTTTTTT is the file type identifier (total of ten uppercase letters/digits/underscores).

<instance\_ID> is the file instance ID (variable length, up to 41 letters/digits/underscores), where the <instance\_ID> string will include creation time/validity time information

- <instance\_ID> = yyyyymmddThhmmss\_yyyyymmddThhmmss\_vvvv
- yyyyymmddThhmmss: date/time strings of validity interval start and stop times
- vvvv: file version number (4 digits starting with 0001).

EEE is the file extension taking 3 possible values:

- “EEF” if header and datablock are contained in a single file
- “HDR” in the case of a header file
- “DBL” in the case of a datablock file

For data products, the file type identifier takes the form

TTTTTTTTTT = ALD\_<u/c flag>\_X\_<product\_ID>

where

“ALD” denotes a data product from the Aladin instrument

<u/c flag> = “U” for unconsolidated (“C” for consolidated is not applicable for Aeolus)

X = “N” for nominal instrument operation and tests

<product\_ID> = “1B” for a Level 1B product and “2B” for a Level 2B product

Note: the valid options for X have been reviewed in response to GSDR RID 166. With the adoption of a range of File\_Class values (“CCCC” above), it is not envisaged that further values for X are needed.

For auxiliary data, the file type identifier takes the form



TTTTTTTTTT = AUX\_PPPPPP

where

“AUX” denotes an auxiliary file

PPPPPP = yyy\_xx for calibration files  
 (yyy denotes the specific type of calibration and xx denotes the processor level generating the file)  
 = “PAR\_xx” for a processing parameter/algorithm settings file  
 (xx denotes the processor level that uses the file)

Three further options are introduced

= “MET\_ss” for auxiliary meteorological data  
 (with the file class CCCC and ss denoting the processing level permitted to use the data, e.g. “OPER\_AUX\_MET\_12”)  
 = “RBC\_ss” for Rayleigh-Brillouin correction data  
 (ss denotes the processor that generates the file or the processing levels permitted to use the data)  
 = “CLM\_ss” for climatology look-up tables  
 (ss denotes the processor that generates the file or the processing levels permitted to use the data)

## 3.2 Format Conventions (XML, KVT, Binary)

Format conventions for XML and KVT syntax are recalled in Table 5 on page 18 and Table 6 on page 19. Binary data types and corresponding sizes in bytes are also recalled in Table 7 on page 20. Note that these conventions are recalled from tables 3-1 and 3-2 of [RD3] and conform to the standards expressed in [AD3].

As shown in Table 5, sizes in XML format are variable. Thus, throughout this document, sizes of parameters and files in XML format (i.e. HDR and EEF files) are indicative only.

### 3.2.1 Usage of Spare fields

Originally the idea of adding Spare fields was intended to allow easy modification of a fileformat without having to rewrite most of the reading and writing subroutines of the software. This argument however is not valid for XML and binary, only maybe for the KVT part of the binary file.

For the xml format, a Spare is a nonsense concept, since the flexibility of xml makes it useless to reserve blanks in a file for future addition of fields. Well programmed XML software does not access its elements by hardcoding indices to fields to be read (maybe except for the case of multiple sibling tags with the same name). Therefore this software will be fully compatible with new file formats that add new XML fields.

If in the KVT part of a file, a Spare is converted or shrunk to allow adding a new field, older reading software may remain usable. This however is not true for the L2BP software, since we systematically check all spare fields to be filled with spaces.

The non-KVT part of a binary file is organised in datasets, described by DataSetDescriptors (DSDs), therefore a change in format of one dataset will not be noticed by the reading and writing code for all the other datasets. This makes spare fields obsolete, with regard to the above mentioned argument to include them. However, during development of the L2BP it has been proven of great value to have certain regions in the binary file that are guaranteed to be filled with zeros. The L2BP systematically checks all these spare fields to be filled with zeros. This largely improves the chance of detecting mistakes in implementing read and write software for a given binary fileformat. Therefore the L2BP team recommends to include spare fields with varying lengths in any future file formats that might be defined.

## 3.3 Specific Field Details

### 3.3.1 Quality Flags

In the different products 1 byte IntAuc data or 2 byte IntAus data is used for bit flag quality fields. In these quality fields bit 1 refers to the most significant bit whereas bit 8 or bit 16 refer to the least significant bit.

Table 5: Format conventions used for headers in XML format

Format	Description	Size bytes	Example
DateTime	<p>Any UTC time uses the “standard with reference” format “UTC=yyyy-mm-ddThh:mm:ss[.uuuuuu]”, where:</p> <ul style="list-style-type: none"> <li>- yyyy is a 4 digit integer representing the year</li> <li>- mm is a 2 digit integer representing the month</li> <li>- dd is a 2 digit integer representing the day</li> <li>- hh is a 2 digit integer representing the hour</li> <li>- mm is a 2 digit integer representing the minutes</li> <li>- ss is a 2 digit integer representing the seconds</li> <li>- uuuuuu is a 6 digit integer representing the micro-seconds.</li> </ul> <p>For maximum consistency with the KVT format used for DBL files, the convention for Aeolus HDR files is that microseconds are not present in the FixedHeader but are present in all other DateTime fields.</p>	23 (Fixed-Header) 30 (non-Fixed-Header)	UTC=2005-03-31T12:00:00 (FixedHeader) UTC=2005-03-31T12:00:00.123456 (all non-FixedHeader DateTimes)
String	array of ASCII encoded characters	variable	“A_STRING”
Enum	array of ASCII encoded characters with a fixed number of valid values	variable	“A_STRING”
Boolean	False or True	variable	False or True
IntAuc	unsigned char integer	variable	“221”
IntAc	signed char integer	variable	“-221”
IntAus	Unsigned short integer	variable	“+65535”
IntAs	signed short integer	variable	“-12828”
IntAul	unsigned long integer	variable	“1010000000”
IntAl	signed long integer	variable	“-1010000000”
IntAd	long long integer	variable	“240000000”
FAdoxy	float with x digits before the decimal point and y digits after	variable	“034.8399”
Spare	array of characters filled with blanks	variable	“ ”

Table 6: Format conventions used for headers in KVT format

Format	Description	Size (bytes)	Example
DateTime	Any UTC time uses the “Envisat with microseconds” format “dd-mmm-yyyy hh:mm:ss.uuuuuu”, where: <ul style="list-style-type: none"> <li>- dd is a 2 digit integer representing the day</li> <li>- mmm is a 3 character string representing the month, e.g., JAN, FEB, etc.</li> <li>- yyyy is a 4 digit integer representing the year</li> <li>- hh is a 2 digit integer representing the hour</li> <li>- mm is a 2 digit integer representing the minutes</li> <li>- ss is a 2 digit integer representing the seconds</li> <li>- uuuuuu is a 6 digit integer representing the micro-seconds.</li> </ul>	27	09-OCT-2007 11:21:32.210146
String	String written with quotes before and after. The text is left justified, e.g., any added blanks should appear at the end of the field string.	variable	“A.STRING”
Enum	String without quotes	variable	“A.STRING”
Boolean	0 (for FALSE) or 1 (for TRUE)	1	0 or 1
IntAuc	Unsigned char integer, written with a ‘+’ at the beginning	4	+221
IntAc	Signed char integer, written with the sign at the beginning	4	-121
IntAus	Unsigned short integer, written with a ‘+’ at the beginning	6	+65535
IntAs	Signed short integer, written with the sign at the beginning	6	-12828
IntAul	Unsigned long integer, written with a ‘+’ at the beginning	11	+4294967295
IntAl	Signed long integer, written with the sign at the beginning	11	-2147483647
IntAd	Signed long long integer, written with the sign at the beginning	21	+0000000000024000000
FAdoxy	Float with x digits before the decimal point and y digits after, written with the sign at the beginning	X+Y+2	+034.8399 (FADO34)
Spare	The space is filled with blanks	40	

Table 7: Data types and corresponding size in bytes for binary data

Format	Description	Size (bytes)	Example
DateTime	<p>Any UTC time uses the Modified Julian Date 2000 (MJD2000) format. In binary format, an MJD2000 time is represented by the format &lt;days&gt;.&lt;seconds&gt;&lt;microseconds&gt;, where:</p> <ul style="list-style-type: none"> <li>• &lt;days&gt; is a 4 byte signed long integer representing the number of days since January 1st, 2000 at 0:0 hour (which may be negative)</li> <li>• &lt;seconds&gt; is a 4 byte unsigned long integer representing the number of seconds elapsed since the beginning of the day</li> <li>• &lt;microseconds&gt; is a 4 byte unsigned long integer representing the number of microseconds elapsed since the last second</li> </ul>	12	
String	Array of characters	variable	A_STRING
Enum	A set of fixed values	variable	A_STRING
Boolean	0 (for FALSE) or 1 (for TRUE)	1	0
IntAuc	Unsigned char integer	1	[0, +255]
IntAc	Signed char integer	1	[-128, +127]
IntAus	Unsigned short integer	2	[0, +65 535]
IntAs	Signed short integer	2	[-32 768, +32 767]
IntAul	Unsigned long integer	4	[0, +4 294 967 295]
IntAl	Signed long integer	4	[-2 147 483 648, +2 147 483 647]
IntAd	Signed long long integer	8	[-9 223 372 036 854 775 808, +9 223 372 036 854 775 807]
FAdoxy	Double precision floating point (See Document ???A-22)???	8	[-1.79e+308, 1.79e+308], [-2.22e-308, 2.22e-308]
Spare	Array of characters filled with space (ASCII 32) characters	variable	

### 3.3.2 Longitude/Latitude

Longitude values are reported with the unit 10-6DegE, where the values range between 0° and 360°. Latitude values are reported with the unit 10-6DegN, where the values range between -90.0° (south pole) and +90.0° (north pole).

## 3.4 General File Structure

All the Aeolus files comply with the Earth Explorer Ground Segment File Format Standard, including auxiliary and non-product files (such as processing report files).

The Aeolus L2B/L2C input and output files follow a general structure containing:

- A Fixed Header (FH) written using the XML standard. This header is identical for all files and is described in Section 3.4.1.
- A Variable Header (VH) which varies from one file type to another. It consists of:
  - A Main Product Header (MPH) written using the XML standard. The MPH is identical for all files and is described in Section 3.4.2.
  - A Specific Product Header written using the XML standard. This is part of the MPH that varies for each product type, and is thus described separately for each product type in the relevant sections.  
All SPH structures will include one or more Data Set Descriptors (DSDs) which describe the format/structure of individual Data Sets in the Data Block portion of the product. The DSD structure is described in Section 3.4.3.
- A Data Block (DBL) containing one or more Data Sets (DS), each consisting of one or more Data Set records (DSRs). Each product will contain different types of DSs and these are described in the relevant sections. Data sets in the Data Block can be of three different types: Measurement Data Sets (MDS), Annotation Data Sets (ADS) or Global Annotation Data Sets (GADS).

For small data volume, all components are stored in the same physical file and the data block is written using the XML standard.

For large data volume, the Data Block is stored in a separate file and has an ASCII header containing a copy of the MPH and SPH (which includes DSDs) written using KVT format.

### 3.4.1 Fixed Header

The structure of the Fixed Header is common to all Earth Explorer products. It is recalled in Table 8, Table 9 and Table 10. An example is given in Figure 2. Note that the FH is written only once in XML in the header section of the L2B/L2C output product file. It is not repeated in the Data Block file. The format applies to all the L2B-related files (including Aux Meteorological Data, Aux L2B\_Param Data and Aux RBC Data).

Table 8: L2B/L2C Fixed Header Content Description

Tag Name	Content Description	Unit	Type	Size (XML)
Fixed.Header	Root tag		Structure	15 0 16
File.Name	Logical file name without the extension		String	11 62 13
File.Description	One line description of the file		String	18 32 20
Notes	Multi-lines free text		String	7 32 9
Mission	String representing the mission name (“Aeolus” for the ADM-Aeolus mission). Note that, in the File.Name, the Mission ID is a two character string (“AE” for the ADM-Aeolus mission)		String	9 6 11

Continued on Next Page...

Tag Name	Content Description	Unit	Type	Size (XML)		
File.Class	OPER (file type as indicated in the file name) or TEST		String	12	4	14
File.Type	The part of the file name that gives the file type. For L2Z measurement products, the file type can be ALD_U_N_2Z, where "2Z" is "2B" or "2C". For explanation of the different valid values see Section 3.1		String	11	10	13
Validity.Period	See Table 9 for structure description		Structure	18	112	19
File.Version	The vvvv part of the file name (see Section 3.1)		Integer	14	4	16
Source	See Table 10 for structure description		Structure	9	172	10
<b>Total size for XML FH in bytes:</b>				<b>699</b>		

- end of table -

Table 9: L2B/L2C Fixed Header Validity\_Period Content Description

Tag Name	Content Description	Unit	Type	Size (XML)		
Validity_Start	Validity start time as specified in the file name. To indicate the beginning of the mission, the special value: "UTC=0000-00-00T00:00:00" can be used.	UTC	DateTime (without micro-seconds)	16	23	18
Validity_Stop	Validity stop time as specified in the file name. To indicate the end of the mission, the special value: "UTC=9999-99-99T99:99:99" can be used.	UTC	DateTime (without micro-seconds)	15	23	17
<b>Total size for XML FH in bytes:</b>				<b>112</b>		

- end of table -

Table 10: L2B/L2C Fixed Header Source Content Description

Tag Name	Content Description	Unit	Type	Size (XML)		
System	"L2_PF" for L2B/L2C product files generated by ECMWF, or "PDS" in case of re-processing at ESRIN. Other options for consideration by ESA: L2B_PF, L2BCPF, etc.		String	8	19	10
Creator	L2BP (official name of L2B processor) or L2CP		String	9	12	11
Creator_Version	Version of L2BP/L2CP used for the generation of the present product file		String	17	12	19
Creation_Date	Date/time of creation	UTC	DateTime	15	23	17
<b>Total size for XML FH Source in bytes:</b>				<b>172</b>		

- end of table -

```
<Fixed_Header>
  <File_Name>AE_TEST_ALD_U_N_2B_20071002T000001_20071002T000002_0001</File_Name>
  <File_Description>Level 2B Product</File_Description>
  <Notes>Room for some
additional remarks</Notes>
  <Mission>Aeolus</Mission>
  <File_Class>TEST</File_Class>
  <File_Type>ALD_U_N_2B</File_Type>
  <Validity_Period>
    <Validity_Start>UTC=2007-10-02T00:00:01</Validity_Start>
    <Validity_Stop>UTC=2007-10-02T00:00:02</Validity_Stop>
  </Validity_Period>
  <File_Version>0001</File_Version>
  <Source>
    <System>LOCAL</System>
    <Creator>L2BP</Creator>
    <Creator_Version>0.1</Creator_Version>
    <Creation_Date>UTC=2006-01-30T15:25:25</Creation_Date>
  </Source>
</Fixed_Header>
```

Figure 2: Example of L2B/L2C Fixed Header.

### 3.4.2 Main Product Header

The structure of the MPH is common to all AEOLUS products. It is detailed in Table 11. It is similar to the MPH structure of L1B products as described in section 3.3.2 of [RD3] and matches the standards expressed in [AD2] and [AD3]. The data types (column 4) are defined in Section 3.2. Note that the MPH is written in XML in the header file and repeated in KVT in the Data Block file. This is why the size is evaluated for both KVT and XML formats in the last two columns.

Table 11: L2B/L2C Main Product Header Content Description

Tag Name	Content Description	Unit	Type	Size (KVT)			Size (XML)		
Main_Product_Header	Root tag (XML format only).		Structure	N/A			22	0	23
Product	Logical file name, i.e., file name excluding the extension		String	9	62	2	9	62	11
Proc_Stage	Processing stage flag: "S" for systematic, "N" for nominal processing (quasi- or close to real-time), "T" for test product, "R" for reprocessed		Enum	11	1	1	12	1	14
Ref_Doc	Reference document describing the product		String	9	23	2	9	23	11
Spare_1			Spare	40	0	1	10	0	11
Acquisition_Station	Acquisition station ID		String	21	20	2	21	20	23
Proc_Center	Processing centre ID, e.g., "L2-PAF"		String	13	6	2	13	6	15
Proc_Time	Time of processing	UTC	DateTime	11	27	2	11	30	13
Software_Ver	Software version number of processing software. Format: name of processor (up to 10 characters)/version number(4 characters)		String	14	14	2	14	14	16
Spare_2			Spare	40	0	1	10	0	11
Sensing_Start	Start time of sensing	UTC	DateTime	15	27	2	15	30	17 l2b
Sensing_Stop	Stop time of sensing	UTC	DateTime	14	27	2	14	30	16 l2b
Spare_3			Spare	40	0	1	10	0	11
Phase	Phase number. If not used set to "X"		Enum	6	1	1	7	1	9
Cycle	Cycle number		IntAuc	6	4	1	7	4	9
Rel_Orbit	Start relative orbit number		IntAs	10	6	1	11	6	13
Abs_Orbit	Start absolute orbit number		IntAus	10	6	1	11	6	13
State_Vector_Time	Time of state vector	UTC	DateTime	19	27	2	19	30	21
Delta_UT1	Delta_UT1 = UT1-UTC	s	FAdo06	10	8	4	11	8	13
X_Position	X position in Earth-fixed reference	m	FAdo73	11	12	4	12	12	14
Y_Position	Y position in Earth-fixed reference	m	FAdo73	11	12	4	12	12	14
Z_Position	Z position in Earth-fixed reference	m	FAdo73	11	12	4	12	12	14
X_Velocity	X velocity in Earth-fixed reference	m/s	FAdo46	11	12	6	12	12	14
Y_Velocity	Y velocity in Earth-fixed reference	m/s	FAdo46	11	12	6	12	12	14
Z_Velocity	Z velocity in Earth-fixed reference	m/s	FAdo46	11	12	6	12	12	14
Vector_Source	Source of orbit vectors (not used by ADM-Aeolus)		String	15	2	2	15	2	17

Continued on Next Page...



Tag Name	Content Description	Unit	Type	Size (KVT)			Size (XML)		
Spare_4			Spare	40	0	1	10	0	11
Utc_Sbt_-Time	Time corresponding to SBT below (not used by ADM-Aeolus)	UTC	DateTime	14	27	2	14	30	16
Sat_Binary_-Time	Satellite Binary Time (not used by ADM-Aeolus)		IntAul	16	11	1	17	11	19
Clock_Step	Clock step size (not used by ADM-Aeolus)	ps	IntAul	11	11	5	12	11	14
Spare_5			Spare	32	0	1	10	0	11
Leap-Utc	Time of occurrence of the leap second	UTC	DateTime	10	27	2	10	30	12
Leap_Sign	Leap second sign (+001 if positive leap second, -001 if negative)		IntAc	10	4	1	11	4	13
Leap_Err	Leap second error. "1" if leap second error occurs during processing segment, "0" otherwise		Boolean	9	1	1	10	1	12
Spare_6			Spare	40	0	1	10	0	11
Product_Err	"1" or "0". If '1', errors have been reported in the product. User should then refer to the SPH or Quality ADS of the product for details of the error condition. '0' otherwise.		Boolean	12	1	1	13	1	15
Tot_Size	Total size of product (#bytes DSR+SPH+MPH)	bytes	IntAd	9	21	8	10	21	12
Sph_Size	Length of SPH (#bytes in SPH)	bytes	IntAl	9	11	8	10	11	12
Num_Dsd	Number of DSDs (19 for L2B files, 25 for L2C files, 4 for AMD files, 1 for RBC files, 1 for L2B_Param files, 1 for L2C_Param)		IntAl	8	11	1	9	11	11
Dsd_Size	Length of each DSDs (#bytes for each DSD, all DSDs shall have the same length)	bytes	IntAl	9	11	8	10	11	12
Num_Data_-Sets	Number of DSs attached (not all DSDs have a DS attached) (13 for L2B files, 17 for L2C files)		IntAl	14	11	1	15	11	17
Spare_7			Spare	40	0	1	10	0	11
<b>Total size for KVT and XML MPH in bytes:</b>				<b>1247</b>			<b>1582</b>		

- end of table -

### 3.4.3 Data Set Descriptor Content Description

Data Set Descriptors contain information on the structure and size of a data set in the Data Block. They have a standard structure common to all Aeolus products, are defined in [AD3], [RD3] and recalled here in Table 12. They are included in the SPH.

Table 12: L2B/L2C Data Set Descriptor Content Description

Tag Name	Content Description	Unit	Type	Size (KVT)			Size (XML)		
Dsd	Root tag (XML format only)		Structure	N/A			6	0	7
DS_Name	DS descriptor ASCII string describing the data set		String	9	28	2	9	28	11
DS_Type	Type of DS. "M" if Measurement DS, "A" if Annotation DS, "G" if Global ADS and "R" if Reference DS (noDS attached)		Enum	8	1	1	9	1	11
Filename	If DS_Type="R", this field contains the name of external file used to process the current product. Otherwise, this field is left blank		String	10	62	2	10	62	12
Ds_Offset	Offset in bytes from the beginning of the file	bytes	IntAd	10	21	8	11	21	13
Ds_Size	Size of Data Set	bytes	IntAl	8	11	8	9	11	11
Num_Dsr	Number of Data Set Records in Data Set		IntAl	8	11	1	9	11	11
Dsr_Size	Size of Data Set Record	bytes	IntAl	9	11	8	10	11	12
Byte_Order	"3210". For binary DS's to designate byte order is most significant byte first.		String	12	4	2	12	4	14
Spare_1			Spare	32	0	1	10	0	11
<b>Total size for KVT and XML DSD in bytes:</b>				<b>288</b>			<b>357</b>		

- end of table -

### 3.5 L2B/L2C/AMD Conventions for Missing Data Indicators

Where it is practical to do so, L2B/L2C and AMD products will adopt conventions for Missing Data Indicators. Such conventions are not a requirement of the Earth Explorer format but are regularly found in meteorological applications. The conventions are that, for integer datatypes, the maximum value is reserved to denote missing data; and for real datatypes (i.e. FAdoxy), the value  $1.7 \times 10^{38}$  is reserved to denote missing data. In practice, different computing platforms will have different representations for  $1.7 \times 10^{38}$  and this is taken into account by applying a tolerance when checking for a Missing Data Indicator: any real value greater than or equal to  $0.99 \times 1.7 \times 10^{38}$  is regarded as a Missing Data Indicator. The use of Missing Data Indicators is additional to the standard practice of reporting PCD parameters to indicate whether product parameters are suitable for use.

## 4 Level 2B/2C Product

This section details the organization and structure of L2B/L2C output products, which are generated using the Level-1B Wind Measurement Product as input to the Level-2B/2C processor.

L2B and L2C product files are defined by a common template. They differ in the presence and values of some header parameters, and in the number of datasets.

The Level-2B/2C Product contains HLOS wind component retrieval results after accumulation of measurements, derived from meteorologically-weighted averages of L1B measurement data, as well as error estimates and reliability data for each wind result. These retrieval results are fully geo-located, indicating latitude, longitude and altitude. In addition, depending on user settings, profile definitions are provided that combine these wind retrieval results into vertical (usually incomplete) vertical profiles.

Note however that a major intended application for the L2B product is its use by the numerical weather prediction community and hence altitude is referenced to a geoid; altitude above the WGS84 ellipsoid can be inferred because the geoid height above the WGS84 reference ellipsoid is also provided in the L2B/L2C Product. Further details are contained in [RD1].

L2C products contain supplementary information derived from processing of Aeolus L1B/L2B data within a data assimilation system. Such information consists of horizontal wind vectors (2 components) at the accumulation scale, associated error estimates, and further information related to the quality of L2B data within the assimilation system. The supplementary information is contained in 4 datasets that are only present for L2C products.

Storage of L2B/L2C wind results and profiles is flexible, and not related to the original BRC definition as used by the L1B data. The result will reflect different selection, accumulation and weighting of L1B measurements according to the meteorological conditions at the measurement locations.

### 4.1 Product Structure

The Level-2B/2C product conforms to the product structure defined in Section 3.4.

#### 4.1.1 File Name

The Level-2B/2C Product file name has the format defined in Section 3.1:

```
AE_CCCC_ALD_U_X_2Z_yyyymmddThhmmss_yyyymmddThhmmss_vvvv.EEE
```

where “2Z” can be “2B” or “2C”. The extension EEE is HDR for the header and DBL for the data block. That is, the Level-2B/2C product consists of two files:

- A header containing a Fixed Header, MPH, and SPH with DSDs. The header is in XML format and has extension EEE = “HDR”.
- A datablock containing a copy of MPH and SPH in KVT format followed by the DataSets in binary format. The data block has the file extension EEE = “DBL”.

#### 4.1.2 File Structure

The Header File contains a Fixed Header and a Variable Header. The Variable Header contains the MPH as described in Section 3.4 and the L2B/L2C SPH. The L2B/L2C SPH is described in Section 4.2 below. The Data Sets in the datablock are described in Section 4.3.

### 4.2 Specific Product Header

The Specific Product Header of L2B/L2C Data Products is detailed in Table 13. Note that some parameters are only present in L2C data products.

Table 13: L2B/L2C Specific Product Header Content Description

Tag Name	Content Description	Unit	Type	Size (KVT)	Size (XML)
Specific_Product_Header	Root tag (XML format only).		Structure	N/A	26 0 27
Sph_Descriptor	Specific Product Header descriptor: ASCII string describing the product		String	16 28 2	16 28 18
Spare_1			Spare	40 0 1	10 0 11
Num-Measurements	Number of L1B measurements used in the product		IntAus	16 6 1	17 5 19
NumMie-Groups	Number of measurement groups generated for the Mie channel		IntAus	13 6 1	14 5 16
NumRayleigh-Groups	Number of measurement groups generated for the Rayleigh channel		IntAus	18 6 1	19 5 21
NumMie-WindResults	Number of Mie channel wind retrievals performed on accumulated measurement data		IntAul	18 11 1	19 10 21
NumRayleigh-WindResults	Number of Rayleigh channel wind retrievals performed on accumulated measurement data		IntAul	23 11 1	24 10 26
NumMie-Profiles	Number of Mie channel wind profiles generated from the individual wind retrievals		IntAus	15 6 1	16 5 18
NumRayleigh-Profiles	Number of Rayleigh channel wind profiles generated from the individual wind retrievals		IntAus	20 6 1	21 5 23
NumAMD-profiles	Number of AMD profiles presented to the L2B processing stage		IntAus	15 6 1	16 5 18
Intersect_Start_Lat	Latitude of the intersection of WGS84 DEM and the satellite line-of-sight for the first measurement that was processed	10-6degN	IntAl	20 11 11	21 9 23
Intersect_Start_Long	Longitude of the intersection of WGS84 DEM and the satellite line-of-sight for the first measurement that was processed	10-6degE	IntAl	21 11 11	22 10 24
Intersect_Stop_Lat	Latitude of the intersection of WGS84 DEM and the satellite line-of-sight for the last measurement that was processed	10-6degN	IntAl	19 11 11	20 9 22
Intersect_Stop_Long	Longitude of the intersection of WGS84 DEM and the satellite line-of-sight for the last measurement	10-6degE	IntAl	20 11 11	21 10 23
Sat_Track	Sub-satellite track heading (nadir) at the sensing start time in the MPH	deg	FAdo36	10 11 6	11 11 13
Spare_2			Spare	40 0 1	10 0 11
Num_Valid_Clear_Mie_Profiles	number of profiles holding at least one valid clear Mie wind retrieval result		IntAus	29 6 1	30 5 32
Num_Valid_Clear_Rayleigh_Prof	number of profiles holding at least one valid clear Rayleigh wind retrieval result		IntAus	30 6 1	31 5 33

Continued on Next Page...

Tag Name	Content Description	Unit	Type	Size (KVT)			Size (XML)		
Num.Valid.- Cloud_Mie.- Profiles	number of profiles holding at least one valid cloud Mie wind retrieval result		IntAus	29	6	1	30	5	32
Num.Valid.- Cloud.- Rayleigh.- Prof	number of profiles holding at least one valid cloud Rayleigh wind retrieval result		IntAus	30	6	1	31	5	33
Num.- Invalid.- Clear_Mie.- Profiles	number of profiles holding only invalid clear Mie wind retrieval results		IntAus	31	6	1	32	5	34
Num.- Invalid.- Clear.- Rayleigh.- Prof	number of profiles holding only invalid clear Rayleigh wind retrieval results		IntAus	32	6	1	33	5	35
Num.- Invalid.- Cloud_Mie.- Profiles	number of profiles holding only invalid cloud Mie wind retrieval results		IntAus	31	6	1	32	5	34
Num.- Invalid.- Cloud.- Rayleigh.- Prof	number of profiles holding only invalid cloud Rayleigh wind retrieval results		IntAus	32	6	1	33	5	35
Num.- Profiles.- Surface_Mie	Number of Mie profiles reported in L2B extending down to the surface		IntAus	25	6	1	26	5	28
Num.- Profiles.- Surface_Ray	Number of Rayleigh profiles reported in L2B extending down to the surface		IntAus	25	6	1	26	5	28
Num.Valid.- Clear.- Winds_L2B.- Mie	Number of valid clear Mie wind retrievals			30	11	1	31	10	33
Num.Valid.- Clear.- Winds_L2B.- Ray	Number of valid clear Rayleigh wind retrievals			30	11	1	31	10	33
Num.Valid.- Cloud.- Winds_L2B.- Mie	Number of valid cloud Mie wind retrievals			30	11	1	31	10	33
Num.Valid.- Cloud.- Winds_L2B.- Ray	Number of valid cloud Rayleigh wind retrievals			30	11	1	31	10	33
Num.- Invalid.- Clear.- Winds_L2B.- Mie	Number of invalid clear Mie wind retrievals			32	11	1	33	10	35

Continued on Next Page...

Tag Name	Content Description	Unit	Type	Size (KVT)	Size (XML)
Num.-Invalid.-Clear.-Winds.L2B.-Ray	Number of invalid clear Rayleigh wind retrievals			32 11 1	33 10 35
Num.-Invalid.-Cloud.-Winds.L2B.-Mie	Number of invalid cloud Mie wind retrievals			32 11 1	33 10 35
Num.-Invalid.-Cloud.-Winds.L2B.-Ray	Number of invalid cloud Rayleigh wind retrievals			32 11 1	33 10 35
Spare_3			Spare	40 0 1	10 0 11
Num.Valid.-Clear.-Winds.L2C.-Mie	Number of valid clear assimilated Mie wind retrievals (only present in L2C products)		IntAul	32 11 1	33 10 35
Num.Valid.-Clear.-Winds.L2C.-Ray	Number of valid clear assimilated Rayleigh wind retrievals (only present in L2C products)		IntAul	32 11 1	33 10 35
Num.Valid.-Cloud.-Winds.L2C.-Mie	Number of valid cloud assimilated Mie wind retrievals (only present in L2C products)		IntAul	32 11 1	33 10 35
Num.Valid.-Cloud.-Winds.L2C.-Ray	Number of valid cloud assimilated Rayleigh wind retrievals (only present in L2C products)		IntAul	32 11 1	33 10 35
Num.-Invalid.-Clear.-Winds.L2C.-Mie	Number of invalid clear assimilated Mie wind retrievals (only present in L2C products)		IntAul	30 11 1	31 10 33
Num.-Invalid.-Clear.-Winds.L2C.-Ray	Number of invalid clear assimilated Rayleigh wind retrievals (only present in L2C products)		IntAul	30 11 1	31 10 33
Num.-Invalid.-Cloud.-Winds.L2C.-Mie	Number of invalid cloud assimilated Mie wind retrievals (only present in L2C products)		IntAul	30 11 1	31 10 33
Num.-Invalid.-Cloud.-Winds.L2C.-Ray	Number of invalid cloud assimilated Rayleigh wind retrievals (only present in L2C products)		IntAul	30 11 1	31 10 33
Spare_4	(only present in L2C products)		Spare	40 0 1	10 0 11
List_of_Dsds	See Table 14 for a description			5472 (L2B) 7200 (L2C)	6823 (L2B) 8965 (L2C)

Continued on Next Page...

Tag Name	Content Description	Unit	Type	Size (KVT)	Size (XML)
Total size for KVT and XML SPH in bytes:				<b>6748 (L2B)</b>	<b>8894 (L2B)</b>
				<b>8861 (L2C)</b>	<b>11665 (L2C)</b>

- end of table -

#### 4.2.1 Data Set Descriptors

The Data Sets listed in Table 14 appear in Aeolus Level-2B/2C products, each described by a DSD in the SPH.

Table 14: Level-2B/2C Data Sets

DSD Number	Name	Description / Comment	DataSet Type	Update Frequency
1	Meas_Map_ADS	DSD for the mapping between L1B and L2B data. See Table 15 for a description	A	1 DSR per Measurement
2	Mie_Grouping_ADS	DSD for the Mie Grouping results. See Table 18 for a description	A	1 DSR per Mie Group
3	Rayleigh_Grouping_Map	DSD for the Rayleigh Grouping results. See Table 18 for a description	A	1 DSR per Rayleigh Group
4	Mie_Geolocation_ADS	DSD for Mie Wind Geolocation Data. See Table 20 for a description	A	1 DSR per Mie Wind Retrieval result
5	Rayleigh_Geolocation_ADS	DSD for Rayleigh Wind Geolocation Data. See Table 20 for a description	A	1 DSR per Rayleigh Wind Retrieval result
6	AMD_Product_Confid_Data_ADS	DSD for AuxMet Product Confidence Data. See Table 22 for a description	A	1 DSR per AuxMet profile
7	Meas_Product_Confid_Data_ADS	DSD for Measurement level Product Confidence Data. See Table 25 for a description	A	1 DSR per Measurement
8	Mie_Wind_Prod_Conf_Data_ADS	DSD for Mie Wind Product Confidence Data. See Table 44 for a description	A	1 DSR per Mie Wind Retrieval result
9	Rayl_Wind_Prod_Conf_Data_ADS	DSD for Rayleigh Wind Product Confidence Data. See Table 46 for a description	A	1 DSR per Rayleigh Wind Retrieval result
10	Mie_Wind_MDS	DSD for Mie Wind Retrieval results. See Table 50 for a description	M	1 DSR per Mie Wind Retrieval result
11	Rayleigh_Wind_MDS	DSD for Rayleigh Wind Retrieval results. See Table 53 for a description	M	1 DSR per Rayleigh Wind Retrieval result
12	Mie_Profile_MDS	DSD for Mie Profile Data. See Table 55 for a description	M	1 DSR per Mie Profile
13	Rayleigh_Profile_MDS	DSD for Rayleigh Profile Data. See Table 55 for a description	M	1 DSR per Rayleigh Profile

Continued on Next Page...

DSD Number	Name	Description / Comment	DataSet Type	Update Frequency
- (L2B) 14 (L2C)	Mie_Assim_PCD_ADS	DSD for L2C-related Mie Assimilation Product Confidence Data (only present in L2C products). See Table 58 for a description	A	1 DSR per Mie Wind Result in L2C products, no DSR in L2B products
- (L2B) 15 (L2C)	Rayl_Assim_PCD_ADS	DSD for L2C-related Rayleigh Assimilation Product Confidence Data (only present in L2C products). See Table 65 for a description	A	1 DSR per Rayleigh Wind Result in L2C products, no DSR in L2B products
- (L2B) 16 (L2C)	Mie_VecWind_MDS	DSD for Mie vector wind results ( only present in L2C products). See Table 70 for a description.	M	1 DSR per Mie Wind result in L2C products, no DSR in L2B products
- (L2B) 17 (L2C)	Rayleigh_VecWind_MDS	DSD for Rayleigh vector wind results ( only present in L2C products). See Table 72 for a description.	M	1 DSR per Rayleigh Wind result in L2C products, no DSR in L2B products
14 (L2B) 18 (L2C)	Aeolus_Level_1B_Product	DSD for input Aeolus Level 1B Product	R	No DS
15 (L2B) 19 (L2C)	Aux_Met_Product	DSD for input Auxiliary Meteorological Data (for re-processing)	R	No DS
16 (L2B) 20 (L2C)	Aeolus_RBC	DSD for Rayleigh-Brillouin lookup tables (auxiliary input file)	R	No DS
17 (L2B) 21 (L2C)	Clim_Product	DSD for climatology look-up tables (auxiliary input file)	R	No DS
18 (L2B) 22 (L2C)	Cal_Product	DSD for calibration coefficients auxiliary input file)	R	No DS
19 (L2B) 23 (L2C)	Level_2B_Proc_Params	DSD for L2B processor settings (auxiliary file).	R	No DS
- (L2B) 24 (L2C)	Aeolus_Level_2B_Product	DSD for input L2B file (only present in L2C products)	R	No DS
- (L2B) 25 (L2C)	Level_2C_Proc_Params		R	No DS

- end of table -

### 4.3 Data Sets

The L2B/C file format uses single HLOS wind retrieval results as basic unit. The number of wind retrieval results may differ for both channels, and depends on the grouping algorithm results and data quality. In addition optional profiles may be defined. The number of height bins in L2B/L2C wind profiles is always 24 (nominal number of height bins). To allow Cross-referencing L1B and L2B/C results, a measurement map is provided. Cross-referencing is implemented by assigning unique identification numbers to each wind retrieval result. Finally, product confidence data on several levels of granularity is generated.

In case a certain value is invalid, the corresponding data field may be filled with a missing data indicator. Currently 1.E37 is used for reals. For integers the maximum allowed value for the specific integer type is used, for example  $2^{*}31-1=2147483647$  is used for 4 byte (long) signed integers).



### 4.3.1 Measurement Map ADS

The Measurement Map Annotation Data Set (ADS) relates the L1B measurements to the L2B wind retrievals. It is defined in table 15. Each range bin in each L1B measurement has a reference id pointing to the L2B wind retrieval result which it was used. In case the measurement level data for a given range bin is invalid or cannot be used for some other reason, the value 0 is used to signal this. Both channels have an independent sections within the measurement map to allow the L2BP a maximum flexibility in its accumulation algorithms.

In addition, each reference is accompanied by a weight which has been used during the accumulation. This allows giving a higher weight to measurement range bins using certain criteria like good SNR or low atmospheric extinction.

Table 15: L2B/L2C Measurement Map ADS Content Description

Tag Name	Description/Comment	Unit	Type	Size (binary)
Start_of_Obs_DateTime	Start date and time of Measurement	UTC	DateTime	12
Mie_Map_of_L1B_-Meas_Used	Map of Mie Measurements used by the L2B accumulations, as defined in table 16		structure	144
Rayleigh_Map_of_L1B_-Meas_Used	Map of Rayleigh Measurements used by the L2B accumulations, as defined in table 16		structure	144
Spare			Spare	8
<b>Total size for Meas_Map_ADS in bytes:</b>				<b>308</b>

- end of table -

Table 16: Meas\_Map Content Description

Tag Name	Description/Comment	Unit	Type	Size (binary)
Bin	list of 24 range bin map entries, as defined in table 17		List of 24 structures of 6 bytes each	144
<b>Total size for Meas_Map in bytes:</b>				<b>144</b>

- end of table -

Table 17: Meas\_Map\_Bin Content Description

Tag Name	Description/Comment	Unit	Type	Size (binary)
Which_L2B_Wind_id	reference to the L2B wind result to which this L1B range bin contributed. It will be set to 0 if not used.		IntAul	4
Weight	Weight used for this L1B range bin while accumulating the signals used to produce the L2B wind result to which this L1B range bin contributed. The valid range is 0-1000		IntAus	2
<b>Total size for Meas_Map_Bin in bytes:</b>				<b>6</b>

- end of table -

### 4.3.2 Mie and Rayleigh Grouping ADS

The Grouping Annotation Data Set (ADS) describes which L1B measurements have been assigned to the same group. Only measurements in the same group may be accumulated to a L2B wind result. Which members of each group will be accumulated depends on the actions of algorithms like classification, and the validity of the data. This ADS is defined in table 18. Both channels have their own copy of this Grouping

ADS to allow independent grouping for them.

Table 18: Grouping ADS Content Description

Tag Name	Description/Comment	Unit	Type	Size (binary)
grouping_result_id	a unique id for this group in this L2B file. Each channel has its own sequence of id numbers and both start counting at 1		IntAus	2
Start_of_Obs_DateTime	Start date and time of Measurement	UTC	DateTime	12
which_L1B_BRC1	L1B BRC number for the measurement at which this group starts		IntAus	2
which_L1B_meas_-within_this_BRC1	L1B measurement number within the above mentioned L1B BRC1 at which this group starts		IntAus	2
which_L1B_BRC2	L1B BRC number for the measurement at which this group ends		IntAus	2
which_L1B_meas_-within_this_BRC2	L1B measurement number within the above mentioned L1B BRC2 at which this group ends		IntAus	2
reason_to_end_this_group	what criterium was used to end this group? Possible values are listed in table 19		IntAuc (Enum)	1
rangebin_causing_group_to_end	at which rangebin was the misalignment detected? Code 0 signals undefined/unused. Code 25 signals a terrain model shift. This field is only defined if reason_to_end_this_group equals rangebin_misalignment		IntAuc	1
Spare			Spare	6
<b>Total size for Grouping ADS in bytes:</b>				<b>30</b>

- end of table -

Table 19: Reasons to end grouping

Name	Description	Value
undefined_end_of_grouping	only used for internal initialisations	0
end_of_file_reached	grouping ended because end of L1B file was reached	1
rangebin_misalignment	grouping ended because the vertical misalignment of rangebins between first and last measurement in the group passed the threshold defined in the L2B AuxPar file	2
max_Horiz_acc_length_reached	grouping ended because the horizontal distance between first and last measurement in the group passed the threshold defined in the L2B AuxPar file	3
max_allowed_gap_betw_meas_rchd	grouping ended because the distance between the first and last missing measurement passed the threshold defined in the L2B AuxPar file	4

- end of table -

### 4.3.3 Geolocation ADS

The Geolocation ADS gives the position, pointing date and time parameters of Mie and Rayleigh HLOS and vector winds. It is repeated for both channels, and thus forms 2 datasets named Mie\_Geoloc ADS (having NumMieWindResults DSR's) and Rayleigh\_Geoloc ADS (having NumRayleighWindResults DSR's). Its DSR structure is described in Table 20. Altitude of Mie or Rayleigh winds are referenced to a geoid according

to the discussion in [RD1], Section 3.2.1. DEM intersections are referenced to the WGS84 ellipsoid as in L1B Geolocation and AOCs ADS (Question: should we translate these to geoid as well?). For the altitude, latitude, longitude, date and time, the values corresponding to the first and last measurement in the accumulation, and to the Center-of-Gravity (CoG) are given. Start\_of\_Obs\_Time in Table 20 is only a time-stamp for the reported observation and precise correspondence with reported geolocation data is not intended. For the use of L2B/L2C products in meteorological applications, it is considered sufficiently precise to report geolocation (latitudes, longitudes, and datetime) as the values of the measurement closest to the exact CoG datetime.

Table 20: L2B/L2C Geolocation ADS Content Description

Tag Name	Description/Comment	Unit	Type	Size (binary)
wind_result_id	a unique id for this wind for this channel in this L2B file. Each channel has its own sequence of id numbers and both start counting at 1		IntAul	4
Start_of_Obs_Time	Date and time of the first measurement used for the current accumulation.	UTC	DateTime	12
WindResult_Geolocation	A single wind geolocation. This structure contains the geolocation of a single wind result. See Table 21 for its structure description.		Wind-Result.-Geolocation structure	115
<b>Total size for Geolocation_ADS in bytes:</b>				<b>131</b>

- end of table -

Table 21: WindResult\_Geolocation Content Description

Tag Name	Description/Comment	Unit	Type	Size (binary)
Altitude_Bottom	Bottom altitude for this accumulation. The altitude is reference to a geoid.	m	IntAl	4
Altitude_COG	Vertical COG altitude for this accumulation. The altitude is reference to a geoid.	m	IntAl	4
Altitude_Top	Top altitude for this accumulation. The altitude is reference to a geoid.	m	IntAl	4
Latitude_Start	Start latitude for this accumulation.	10-6 degN	IntAl	4
Latitude_COG	CoG latitude for this accumulation.	10-6 degN	IntAl	4
Latitude_Stop	Stop latitude for this accumulation.	10-6 degN	IntAl	4
Longitude_Start	Start longitude for this accumulation.	10-6 degE	IntAl	4
Longitude_COG	CoG longitude for this accumulation.	10-6 degE	IntAl	4
Longitude_Stop	Stop longitude for this accumulation.	10-6 degE	IntAl	4
DateTime_Start	Start Date and time for the current accumulation.	UTC	DateTime	12
DateTime_COG	CoG Date and time of the current accumulation.	UTC	DateTime	12
DateTime_Stop	Stop Date and time of the current accumulation.	UTC	DateTime	12
LOS_Azimuth	Azimuth of the target-to-satellite pointing vector.	deg	FAdoxy	8

Continued on Next Page...

Tag Name	Description/Comment	Unit	Type	Size (binary)
LOS_Elevation	Elevation of the target-to-satellite pointing vector	deg	FAdoxy	8
LOS_Satellite_Velocity	Line-of-sight velocity of the satellite	m/s	FAdoxy	8
Lat_of_DEM_-Intersection	Latitude of DEM intersection for the CoG of the current accumulation	10-6 degN	IntAl	4
Lon_of_DEM_-Intersection	Longitude of DEM intersection for the CoG of the current accumulation	10-6 degE	IntAl	4
Alt_of_DEM_-Intersection	Altitude of DEM intersection for the CoG of the current accumulation	m	IntAl	4
WGS84_to_Geoid_-Altitude	Height of geoid above WGS84 ellipsoid.	m	IntAl	4
Spare			Spare	3
<b>Total size for WindResult_Geolocation in bytes:</b>				<b>115</b>

- end of table -

#### 4.3.4 L2B AMD Product Confidence Data (PCD) ADS

The L2BP checks certain aspects of the AMD input file and will report the results in the L2B AMD PCD parameters described in Table 22 below.

Table 22: L2B AMD Product Confidence Data ADS Content Description

Tag Name	Description/Comment	Unit	Type	Size (binary)
Start_of_Obs_DateTime	Start date and time of Measurement	UTC	DateTime	12
L2B_AMD_Screening	Data structure describing the screening of each profile in the AMD input file to the L2BP, as defined in Table 23.		structure	22
Spare			Spare	20
<b>Total size for L2B_AMD_PCD_ADS in bytes:</b>				<b>54</b>

- end of table -

Table 23: L2B\_AMD\_Screening Content Description

Tag Name	Description/Comment	Unit	Type	Size (binary)
L2B_AMD_Screening_-QC	A code describing a problem which prevents using this L2B AMD profile (see Table 24 for a list of valid values).		IntAuc	1
L2B_AMD_Screening_-QC_Flags	Flags describing problems which prevent using this L2B AMD file. Bit 1 : TBD Bit 2 : TBD ... Bit 8 : TBD		IntAuc	1
Spare			Spare	20
<b>Total size for L2B_AMD_Screening in bytes:</b>				<b>22</b>

- end of table -

Table 24: Valid values for the L2B\_AMD\_Screening\_QC field of the L2B\_AMD\_Screening structure

Numerical value	Name	Description
0	L2B_AMD_OK	L2B AMD contents seems OK
1	L2B_AMD_Corrupt_Header	L2B AMD datafile does not match format definition (header problem)
2	L2B_AMD_Corrupt_Profile	L2B AMD datafile does not match format definition (problem in the file format definition of one of the profiles)
3	L2B_AMD_Unlikely_Profile	L2B AMD datafile has strange, unphysical values, in one of its profiles
...		

- end of table -

#### 4.3.5 L2B Meas Product Confidence Data (PCD) ADS

The L2BP will report a number of results on measurement level in the L2B Meas PCD ADS, as defined in Table 25 below. This includes house keeping data, AMD collocation results, L1B input screening results and classification results.

Note that the L2BP treats the data as a continuous stream of measurements, and forgets about the original BRC definitions in the L1B product. To allow referencing the L2B results to the L1B input data, each L2B measurement records the index of the original L1B BRC from which it was taken, and the index of the measurement within that original L1B BRC.

Table 25: L2B Measurement Product Confidence Data ADSR Content Description

Tag Name	Description/Comment	Unit	Type	Size (binary)
Start_of_Obs_DateTime	Start date and time of Measurement	UTC	DateTime	12
L1B_BRC_number	The index of the original L1B BRC from which this L2B measurement was taken,		IntAus	2
L1B_Meas_number	The index of the measurement within the above mentioned original L1B BRC from which this L2B measurement was taken.		IntAus	2
L2B_AMD_Collocation	Structure describing which AMD profile was used, and what the Match Up results are (see Table 26)		structure	20
L1B_Input_Screening	Structure describing any problems found during reading of the L1B datafile (see Table 28)		structure	128
L2B_Mie_Classification_QC	Structure describing QC parameters resulting from the Mie Classification algorithm (see Table 39)		structure	483
L2B_Rayleigh_Classification_QC	Structure describing QC parameters resulting from the Rayleigh Classification algorithm (see Table 42)		structure	482
Spare			Spare	20
<b>Total size for L2B_Meas_PCD_ADS in bytes:</b>				<b>1149</b>

- end of table -

Table 26: L2B/L2C AMD Collocation Content Description

Tag Name	Description/Comment	Unit	Type	Size (binary)
matching_AMD_profile	AMD profile number that was found to match with the current measurement		IntAus	2
matchup_QC	code that specifies whether matchup was successful or not, and if not it gives a reason why it failed (see table 27 for possible values)		IntAuc	1
distance	actual distance between this measurement and the selected AuxMet profile	km	FAdoxy	8
time_difference	actual time difference between this measurement and the selected AuxMet profile		FAdoxy	8
Spare			Spare	1
<b>Total size for L2B_AMD_Collocation in bytes:</b>				<b>20</b>

- end of table -

Table 27: Valid values for the matchup\_QC field of the L2B/L2C-AMD\_Collocation structure

Numerical value	Name	Description
0	Matchup_OK	Matchup seems OK
1	Matchup_Failed_dummyprofnr	The requested index for dummy matchup was not available in the AMD input file. This may happen if the L1B product has more BRC's than the AMD file has profiles (for classic grouping) or if the L2B generates more groups than the AMD file has profiles (for advanced grouping)
10	Matchup_Failed_timewindow	Not a single AuxMet profile was found to be within the requested time window, even though some of them seem to be within the requested distance threshold.
11	Matchup_Failed_distance	Not a single AuxMet profile was found to be within the requested distance threshold, even though some of them seem to be inside the requested time window
12	Matchup_Failed_timeanddistance	Not a single AuxMet profile did match either the requested distance threshold or the requested time window.
254	Matchup_Failed_invalid_method	The selected matchup method was invalid. This will never occur since the processor will exit with an error in this case.
255	Matchup_Undefined	only for internal use; used for initialising the datastructure

- end of table -

Table 28: L2B/L2C Product Confidence Data L1B\_Input\_Screening Content Description

Tag Name	Description/Comment	Unit	Type	Size (binary)
L1B_Obs_Scr	A structure that stores L1B BRC Obs level screening results on measurement level (see Table 29). This is needed because a L2B group no longer corresponds by definition to a single L1B BRC		structure	6
Mie_Meas	structure describing the problems found for this Mie measurement (see Table 31).		structure	51
Rayleigh_Meas	structure describing the problems found for this Rayleigh measurement (see Table 35).		structure	51
Spare			Spare	20
<b>Total size for L2B_PCD L1B_Input_Screening in bytes:</b>				<b>128</b>

- end of table -

Table 29: L2B/L2C PCD L1B Observation Screening Content Description

Tag Name	Description/Comment	Unit	Type	Size (binary)
Obs_Screening	a field that stores a code indicating whether the L1B Observation level screening was passed for the BRC to which this measurement belongs. Possible values are listed in Table 30		IntAuc	1
Obs_Screening_Flags1	TBD		IntAuc	1
Obs_Screening_Flags2	TBD		IntAuc	1
Obs_Screening_Flags3	TBD		IntAuc	1
Obs_Screening_Flags4	TBD		IntAuc	1
Obs_Screening_Flags5	TBD		IntAuc	1
<b>Total size for L2B_PCD L1B_Input_Screening in bytes:</b>				<b>6</b>

- end of table -

NOTE: the table below is to be reconsidered. Do we really need all these items? For example the file reading codes will never occur in a product file since the processor will quit with an error condition if malformed files are encountered.

Table 30: Valid values for the Obs\_Screening field of the L2B/L2C PCD L1B\_Input\_Screening structure.

Numerical value	Name	Description
File reading related:		
0	L1B_File_OK	L1B file reading was succesfull
1	L1B_HDR_Corrupted	L1B file does not match the format definition (a problem was present in one of the headers)
2	L1B_BRC_Corrupted	L1B file does not match the format definition (a problem was present in the binary data for this BRC/Obs)
...		
Laser related:		
10	L1B_Laser_Freq_Unlocked	nmeas with laser_freq_unlocked above a threshold (=1?)

Continued on Next Page...

Numerical value	Name	Description
11	L1B_Ref_Pulses_Unlocked	nrefpulses with laser_freq_unlocked above a threshold (=1?)
12	L1B_Laser_Freq_Offset	average laser freq. offset above a threshold (=... MHz?)
13	L1B_Laser_UV_Energy	average laser UV energy below a threshold (=... mJ?)
14	L1B_Laser_Freq_Offs_Stdev	Standard deviation for laser frequency offset above a threshold(=...MHz?)
15	L1B_Laser_UV_Energy_Stdev	Standard deviation for laser pulse UV energy above a threshold (=... mJ?)
16	L1B_Mie_Mean_Emit_Freq	Mie mean emitted frequency out of valid range
17	L1B_Mie_Emit_Freq_Stdev	Mie emitted frequency standard deviation is out of valid range
18	L1B_Rayl_Mean_Emit_Freq	Rayleigh mean emitted frequency out of valid range
19	L1B_Rayl_Emit_Freq_Stdev	Rayleigh emitted frequency standard deviation is out of valid range
...		
Satellite related:		
20	L1B_Sat_Not_on_Target	nmeas with sat_not_on_target above a threshold (=1?)
...		
Measurement related:		
30	L1B_Mie_corrupt	nmeas with corrupt Mie meas. above a threshold (=1?)
31	L1B_Rayleigh_corrupt	nmeas with corrupt Rayleigh meas. above a threshold (=1?)
32	L1B_Mie_Ref_Pulses_Corrupt	nmeas with corrupt Mie ref. pulses above a threshold (=1?)
33	L1B_Rayl_Ref_Pulses_Corrupt	nmeas with corrupt Rayleigh ref. pulses above a threshold (=1?)
...		
Combinations:		
40	L1B_Mie_Invalid_Meas	Num_of_mie_invalid_measurements above a threshold (=1?)
41	L1B_Mie_Invalid_Ref_Pulses	Num_of_mie_invalid_reference_pulse above a threshold (=1?)
42	L1B_Rayl_Invalid_Meas	Num_of_rayleigh_invalid_measurements above a threshold (=1?)
43	L1B_Rayl_Invalid_Ref_Pulses	Num_of_rayleigh_invalid_reference_pulse above a threshold (=1?)
44	L1B_Invalid_Num_Mie_Peaks	TBD
...		
General:		
255	L1B_Obs_Scr_undefined	only for internal use; used for initialising the datastructure
...		

- end of table -



Table 31: L2B/L2C Product Confidence Data L1B Mie\_Meas screening Content Description

Tag Name	Description/Comment	Unit	Type	Size (binary)
Meas_QC	A code describing a problem which prevents using this Mie measurement (see Table 32 for a list of valid values).		IntAuc	1
Meas_QC.Flags	Flags describing problems which prevent using this Mie Measurement. Bit 1 : TBD Bit 2 : TBD ... Bit 8 : TBD		IntAuc	1
Bin_Screening	List of 24 structures describing the problems found for each Mie measurement Bin (see Table 33)		list of 24 structures	48
Spare			Spare	1
<b>Total size for L2B_PCD_L1B_Mie_Meas_Screening in bytes:</b>				<b>51</b>

- end of table -

Table 32: Valid values for the L1B\_Mie\_Meas\_QC field of the L2B/L2C Product Confidence Data L1B Mie\_Meas Screening structure

Numerical value	Name	Description
0	L1B_Mie_Meas_OK	L1B Mie measurement contents seems OK
1	L1B_Mie_Meas_Invalid_Ref_Pulses	num_of_mie_invalid_reference_pulses above a threshold (=1?)
2	L1B_Avg_Laser_Freq_Offset	Avg_Laser_Frequency_Offset outside allowed range
3	L1B_Avg_UV_Energy	Avg_UV_Energy outside allowed range
4	L1B_Laser_Freq_Offset_Stdev	Laser_Frequency_Offset_Std_Dev outside allowed range
5	L1B_UV_Energy_Std_Dev	UV_Energy_Std_Dev outside allowed range for this measurement
6	L1B_Vel_of_Att_Uncertainty_Error	Velocity_of_Attitude_Uncertainty_Error outside allowed range
7	L1B_Mie_Mean_Emitted_Freq	Mie_Mean_Emitted_Frequency outside allowed range
8	L1B_Mie_Emitted_Freq_Stdev	Mie_Emitted_Frequency_Std_Dev outside allowed range
9	L1B_Meas_Reference_Pulse_FWHM	Mie Measurement Reference_Pulse_FWHM outside allowed range
255	L1B_Mie_Meas_Undefined	only for internal use; used for initialising the datastructure
...		

- end of table -

Table 33: L2B/L2C Product Confidence Data L1B Mie\_Meas\_Bin screening Content Description

Tag Name	Description/Comment	Unit	Type	Size (binary)
Bin_QC	A code describing a problem which prevents using this Mie measurement bin (see Table 34 for a list of valid values).		IntAuc	1
Bin_QC_Flags	Flags describing problems which prevent using this Mie measurement bin. Bit 1 : TBD Bit 2 : TBD ... Bit 8 : TBD		IntAuc	1
<b>Total size for L2B_PCD L1B_Mie_Meas_Bin_Screening in bytes:</b>				<b>2</b>

- end of table -

Table 34: Valid values for the L1B\_Mie\_Meas\_Bin\_QC field of the L1B Mie\_Meas\_Bin Screening structure

Numerical value	Name	Description
0	L1B_Mie_Bin_OK	L1B Mie Bin contents seems OK
1	L1B_Mie_Bin_Invalid	this Mie measurement Bin has been flagged invalid by the L1BP
2	L1B_Scattering_Ratio	Scattering_Ratio_Mie not within valid range
3	L1B_Mie_SNR	Mie_Signal_to_Noise_Ratio is below the processing threshold
50	L1B_Bin_Contains_Surface	the ground surface was detected inside this range bin
51	L1B_Bin_Contains_Surface_DEM	the ground surface is inside this range bin according to the DEM and the remaining bin thickness is too small to be used
52	L1B_Bin_Below_Surface	this range bin is below the surface (surface was detected in the signal of a range bin above this one)
53	L1B_Bin_Below_Surface_DEM	this range bin is below the surface according to the DEM
...		

- end of table -

Table 35: L2B/L2C Product Confidence Data L1B Rayleigh\_Meas screening Content Description

Tag Name	Description/Comment	Unit	Type	Size (binary)
Meas_QC	A code describing a problem which prevents using this Rayleigh measurement (see Table 36 for a list of valid values).		IntAuc	1
Meas_QC_Flags	Flags describing problems which prevent using this Rayleigh Measurement. Bit 1 : TBD Bit 2 : TBD ... Bit 8 : TBD		IntAuc	1

Continued on Next Page...

Tag Name	Description/Comment	Unit	Type	Size (binary)
Bin_Screening	List of 24 structures describing the problems found for each Rayleigh measurement Bin (see Table 37)		list of 24 structures	48
Spare			Spare	1
<b>Total size for L2B_PCD_L1B_Rayl_Meas_Screening in bytes:</b>				<b>51</b>

- end of table -

Table 36: Valid values for the L1B\_Rayleigh\_Meas\_QC field of the L1B Rayleigh\_Meas Screening structure

Numerical value	Name	Description
0	L1B_Rayleigh_Meas_OK	L1B Rayleigh measurement contents seems OK
1	L1B_Rayleigh_Meas_Invalid_Ref_Pulses	num_of_rayleigh_invalid_reference_pulses above a threshold (=1?)
2	L1B_Avg_Laser_Freq_Offset	Avg_Laser_Frequency_Offset outside allowed range
3	L1B_Avg_UV_Energy	Avg_UV_Energy outside allowed range
4	L1B_Laser_Freq_Offset_Stdev	Laser_Frequency_Offset_Std_Dev outside allowed range
5	L1B_UV_Energy_Std_Dev	UV_Energy_Std_Dev outside allowed range for this measurement
6	L1B_Vel_of_Att_Uncertainty_Error	Velocity_of_Attitude_Uncertainty_Error outside allowed range
7	L1B_Rayleigh_Mean_Emitted_Freq	Rayleigh_Mean_Emitted_Frequency outside allowed range
8	L1B_Rayleigh_Emitted_Freq_Stdev	Rayleigh_Emitted_Frequency_Std_Dev outside allowed range
255	L1B_Rayleigh_Meas_Undefined	only for internal use; used for initialising the datastructure
...		

- end of table -

Table 37: L2B/L2C Product Confidence Data L1B Rayleigh\_Meas\_Bin screening Content Description

Tag Name	Description/Comment	Unit	Type	Size (binary)
Bin_QC	A code describing a problem which prevents using this Rayleigh measurement bin (see Table 38 for a list of valid values).		IntAuc	1
Bin_QC_Flags	Flags describing problems which prevent using this Rayleigh measurement bin. Bit 1 : TBD Bit 2 : TBD ... Bit 8 : TBD		IntAuc	1
<b>Total size for L2B_PCD_L1B_Rayleigh_Meas_Bin_Screening in bytes:</b>				<b>2</b>

- end of table -

Table 38: Valid values for the L1B\_Rayleigh\_Meas\_Bin\_QC field of the L1B Rayleigh\_Meas\_Bin Screening structure

Numerical value	Name	Description
0	L1B_Rayleigh_Bin_OK	L1B Rayleigh Bin contents seems OK
1	L1B_Rayleigh_Meas_Bin_Invalid	this Rayleigh measurement Bin has been flagged invalid by the L1BP
2	L1B_Rayleigh_SNR_A	Rayleigh_Signal_to_Noise_Ratio_Channel_A outside valid range
3	L1B_Rayleigh_SNR_B	Rayleigh_Signal_to_Noise_Ratio_Channel_B outside valid range
50	L1B_Bin_Contains_Surface	the ground surface was detected inside this range bin
51	L1B_Bin_Contains_Surface_DEM	the ground surface is inside this range bin according to the DEM and the remaining bin thickness is too small to be used
52	L1B_Bin_Below_Surface	this range bin is below the surface (surface was detected in the signal of a range bin above this one)
53	L1B_Bin_Below_Surface_DEM	this range bin is below the surface according to the DEM
...		

- end of table -

Table 39: L2B/L2C Product Confidence Data L2B\_Mie\_Meas\_Classification\_QC Content Description

Tag Name	Description/Comment	Unit	Type	Size (binary)
L2B_Mie_Meas_Bin-Classification	List of 24 structures describing the results of the Mie classification algorithm for each measurement bin (see Table 40)		list of 24 structures	480
Spare			Spare	3
<b>Total size for L2B_PCD_L2B_Mie_Meas_Class_QC in bytes:</b>				<b>483</b>

- end of table -

NOTE: the flags below are to be reconsidered. The current software does not fill these flags. Do we really need all these items? For example we have no algorithms to detect precipitation at the moment.

Table 40: L2B/L2C Product Confidence Data L2B\_Mie\_Meas\_Bin\_-  
 Classification\_QC Content Description

Tag Name	Description/Comment	Unit	Type	Size (binary)
L2B_Mie_Meas_Bin_- Class_Flags1	First byte of 8 flags describing classification properties for the current Mie measurement rangebin. Bit 1 (L2B_Mie_Class_Cloud_Above) : a cloud was detected in a range bin higher than the current range bin Bit 2 (L2B_Mie_Class_Cloud) : this rangebin contains a cloud Bit 3 (L2B_Mie_Class_Maybe_Cloud) : this rangebin contains possibly a cloud, but the backscatter is close to the threshold Bit 4 (L2B_Mie_Class_Aerosol) : Mie backscatter is present, but it is not a cloud Bit 5 (L2B_Mie_Class_Precipitation) : Precipitation is present in this range bin Bit 6 (L2B_Mie_Class_No_Extinction) : No extinction is known for this range bin Bit 7 (L2B_Mie_Class_Unknown_Scatterer) : the value encountered in this rangebin for backscatter is unphysical for clouds Bit 8 (L2B_Mie_Class_Broken_Clouds) : this range bin contains a broken cloud layer (currently only used for Obs range bins)		IntAuc	1
L2B_Mie_Meas_Bin_- Class_Flags2	Second byte of 8 flags describing classification properties for the current Mie measurement rangebin. Bit 1 (L2B_Mie_Class_Convective_Clouds) : this range bin contains convective clouds Bit 2 (L2B_NWP_Data_Used) : Flag indicating that NWP data was used to determine the classification of this rangebin ... Bit 8 : TBD		IntAuc	1
L2B_Reliability	A measure for the reliability of the classification result for this rangebin		FAdoxy	8
Backscatter_ratio	Backscatter ratio deduced for this rangebin		FAdoxy	8
Applied_ScatRatio_- Method	Method applied to deduce Backscatter ratio for this rangebin (see Table 41).		IntAuc	1
Spare			Spare	1
<b>Total size for L2B_PCD_L2B_Mie_Meas_Bin_Class_QC in bytes:</b>				<b>20</b>

- end of table -

Table 41: Valid values for the Applied\_ScatRatio\_Method field of the L2B\_Mie\_Meas\_Bin\_Classification\_QC structure (compare also the strings used by the L2B AuxPar file, see table 101)

Numerical value	Name	Description
0	Scat_Ratio_Undefined	only for internal use; used for initialising the datastructure
1	Scat_Ratio_from_L1B	

Continued on Next Page...

Numerical value	Name	Description
2	Scat_Ratio_from_L1B_refined	
3	Scat_Ratio_from_MieRayl	
4	Scat_Ratio_from_RaylOnly	
5	Scat_Ratio_One_If_No_Mie	
...		
99	Scat_Ratio_Dont_Use	

- end of table -

Table 42: L2B/L2C Product Confidence Data L2B\_Rayleigh\_-  
 Meas\_Classification\_QC Content Description

Tag Name	Description/Comment	Unit	Type	Size (binary)
L2B_Rayleigh_Meas_- Bin_Classification	List of 24 structures describing the results of the Rayleigh classification algorithm for each measurement bin (see Table 43)		list of 24 structures	480
Spare			Spare	2
<b>Total size for L2B_PCD_L2B_Rayleigh_Meas_Class_QC in bytes:</b>				<b>482</b>

- end of table -

NOTE: the flags below are to be reconsidered. The current software does not fill these flags. Do we really need all these items? For example we have no algorithms to detect precipitation at the moment.

Table 43: L2B/L2C Product Confidence Data L2B\_Rayleigh\_-  
 Meas\_Bin\_Classification\_QC Content Description

Tag Name	Description/Comment	Unit	Type	Size (binary)
L2B_Rayleigh_Meas_- Bin_Class_Flags1	First byte of 8 flags describing classification properties for the current Rayleigh measurement rangebin. Bit 1 (L2B_Rayl_Class_Cloud_Above) : a cloud was detected in a range bin higher than the current range bin Bit 2 (L2B_Rayl_Class_Cloud) : this rangebin contains a cloud Bit 3 (L2B_Rayl_Class_Maybe_Cloud) : this rangebin contains possibly a cloud, but the backscatter is close to the threshold Bit 4 (L2B_Rayl_Class_Aerosol) : Mie backscatter is present, but it is not a cloud Bit 5 (L2B_Rayl_Class_Precipitation) : Precipitation is present in this range bin Bit 6 (L2B_Rayl_Class_No_Extinction) : No extinction is known for this range bin Bit 7 (L2B_Rayl_Class_Unknown_Scatterer) : the value encountered in this rangebin for backscatter is unphysical for clouds Bit 8 (L2B_Rayl_Class_Broken_Clouds) : this range bin contains a broken cloud layer (currently only used for Obs range bins)		IntAuc	1

Continued on Next Page...

Tag Name	Description/Comment	Unit	Type	Size (binary)
L2B_Rayleigh_Meas.- Bin_Class_Flags2	Second byte of 8 flags describing classification properties for the current Rayleigh measurement rangebin. Bit 1 (L2B_Rayl_Class_Convective_Clouds) : this range bin contains convective clouds Bit 2 (L2B_NWP_Data_Used) : Flag indicating that NWP data was used to determine the classification of this rangebin ... Bit 8 : TBD		IntAuc	1
L2B_Reliability	A measure for the reliability of the classification result for this rangebin		FAdoxy	8
Backscatter_ratio	Backscatter ratio deduced for this rangebin		FAdoxy	8
Applied_ScatRatio.- Method	Method applied to deduce Backscatter ratio for this rangebin (see Table 41).		IntAuc	1
Spare			Spare	1
<b>Total size for L2B_PCD_L2B_Mie_Meas_Bin_Class_QC in bytes:</b>				<b>20</b>

- end of table -

#### 4.3.6 L2B/L2C Mie Wind Product Confidence Data ADS

Table 44: L2B/L2C Mie Wind Product Confidence Data L2B.-  
Mie\_Processing\_QC ADS Content Description

Tag Name	Description/Comment	Unit	Type	Size (binary)
wind_result_id	unique L2B wind result identification number for this L2B file		IntAul	4
Start_of_Obs_DateTime	Date and time of first measurement used for this wind result	UTC	DateTime	12
Mie_Wind_QC	Structure in which the wind retrieval output QC parameters for the Mie channel are collected (see Table 45 for a description)		structure	101
Spare			Spare	20
<b>Total size for L2B_Mie_WInd_PCD_ADS in bytes:</b>				<b>137</b>

- end of table -

Table 45: Mie channel wind retrieval output QC parameters

Tag Name	Description/Comment	Unit	Type	Size (binary)
Hlos_Error_Estimate	Error estimate reported by the Mie processing algorithm, as defined in [RD7]	m/s	FAdoxy	8

Continued on Next Page...

Tag Name	Description/Comment	Unit	Type	Size (binary)
flags1	First flag describing Mie processing results for the current wind result. Bit 1: MaxItLorFit threshold reached for measurement fit Bit 2: ResErrThresh threshold reached for measurement fit Bit 3: MaxItNonLinOpt threshold reached for measurement fit Bit 4: PeakHeightLoThresh threshold reached for measurement fit Bit 5: PeakHeightUpThresh threshold reached for measurement fit Bit 6: FWHMLoThresh threshold reached for measurement fit Bit 7: FWHMUpThresh threshold reached for measurement fit Bit 8: PeakLocThresh threshold reached for measurement fit		IntAuc	1
flags2	Second flag describing Mie processing results for the current wind result. Bit 1: MaxItLorFit threshold reached for internal reference fit Bit 2: ResErrThresh threshold reached for internal reference fit Bit 3: MaxItNonLinOpt threshold reached for internal reference fit Bit 4: PeakHeightLoThresh threshold reached for internal reference fit Bit 5: PeakHeightUpThresh threshold reached for internal reference fit Bit 6: FWHMLoThresh threshold reached for internal reference fit Bit 7: FWHMUpThresh threshold reached for internal reference fit Bit 8: PeakLocThresh threshold reached for internal reference fit		IntAuc	1
flags3	Third flag describing Mie processing results for the current wind result. Bit 1: SNR threshold failed for this wind result (signal was too low) Bit 2: TBD Bit 3: TBD Bit 4: TBD Bit 5: TBD Bit 6: TBD Bit 7: TBD Bit 8: TBD		IntAuc	1
IntRef_Fitting_Amplitude	Amplitude of the curve used for fitting the internal reference spectrum		FAdoxy	8
IntRef_Fitting_Residual	Residual after the fit to the internal reference spectrum is performed (should also give an idea of the reliability of the fit)		FAdoxy	8
IntRef_Fitting_Offset	Offset of the curve used for fitting the internal reference spectrum		FAdoxy	8
IntRef_Fitting_FWHM	FWHM of the curve used for fitting internal reference the spectrum.		FAdoxy	8

Continued on Next Page...



Tag Name	Description/Comment	Unit	Type	Size (binary)
Fitting_Amplitude	Amplitude of the curve used for fitting the Mie spectrum		FAdoxy	8
Fitting_Residual	Residual after the fit to the Mie spectrum is performed (should also give an idea of the reliability of the fit)		FAdoxy	8
Fitting_Offset	Offset of the curve used for fitting the Mie spectrum		FAdoxy	8
Fitting_FWHM	FWHM of the curve used for fitting the Mie spectrum. This gives a measure of the wind variability in this rangebin		FAdoxy	8
Mie_SNR	SNR of the Mie spectrum		FAdoxy	8
Extinction	Extinction used to determine the height assignment for this wind result	1/m	FAdoxy	8
Scattering_Ratio	Scattering_Ratio used to estimate the extinction for this wind result		FAdoxy	8
Mie_Background_High	A value of 1 indicates that this data was taken during daylight, so possibly the background radiation level is high.		IntAuc	1
Spare			Spare	1
<b>Total size for L2B_Mie_Wind_QC in bytes:</b>				<b>101</b>

- end of table -

#### 4.3.7 L2B/L2C Rayleigh Wind Product Confidence Data ADS

Table 46: L2B/L2C Rayleigh Wind Product Confidence Data  
 L2B\_Rayleigh\_Processing\_QC ADS Content Description

Tag Name	Description/Comment	Unit	Type	Size (binary)
wind_result_id	unique L2B wind result identification number for this L2B file		IntAul	4
Start_of_Obs_DateTime	Date and time of first measurement used for this wind result	UTC	DateTime	12
Rayleigh_Wind_QC	Structure in which the wind retrieval output QC parameters for the Rayleigh channel are collected (see Table 47 for a description)		structure	22
Spare			Spare	20
<b>Total size for L2B_Rayleigh_Wind_PCD_ADS in bytes:</b>				<b>58</b>

- end of table -

Table 47: Rayleigh channel wind retrieval output QC parameters

Tag Name	Description/Comment	Unit	Type	Size (binary)
Hlos_Error_Estimate	Error estimate reported by the Rayleigh processing algorithm, as defined in [RD7]	m/s	FAdoxy	8

Continued on Next Page...

Tag Name	Description/Comment	Unit	Type	Size (binary)
flags1	First flag describing Rayleigh processing results for the current wind result. Bit 1: missing usefull reference pulse signal Rayleigh Channel A Bit 2: missing usefull reference pulse signal Rayleigh Channel B Bit 3: missing usefull signal Rayleigh Channel A Bit 4: missing usefull signal Rayleigh Channel B Bit 5: threshold check on RRmes_weighted failed Bit 6: missing RRmes_weighted value Bit 7: missing RR_RefPulse_weighted value Bit 8: missing p_ref value		IntAuc	1
flags2	Second flag describing Rayleigh processing results for the current wind result. Bit 1: missing T_ref value Bit 2: missing rho_weighted value Bit 3: corr0 threshold failed Bit 4: corr0dR threshold failed Bit 5: corr0dT threshold failed Bit 6: corr0dP threshold failed Bit 7: corr0drho threshold failed Bit 8: corr0_RefPulse threshold failed		IntAuc	1
flags3	Third flag describing Rayleigh processing results for the current wind result. Bit 1: missing iliad_los_velocity value Bit 2: missing spacecraft_los_velocity value Bit 3: missing ground_corr_velocity value Bit 4: missing internal_reference_los_velocity value Bit 5: TBD Bit 6: TBD Bit 7: TBD Bit 8: TBD		IntAuc	1
Scattering_Ratio	Scattering_Ratio used to estimate the Mie signal used in Mie decontamination for this wind result		FAdoxy	8
Scattering_Ratio-Method	Scattering_Ratio_Method used to determine the Scattering_Ratio rho for this wind result (see Table 49 for a list of valid values)		IntAuc	1
Rayleigh_Background-High	A value of 1 flags that this data was taken during daylight, so possibly the background radiation level is high.		IntAuc	1
Spare			Spare	1
<b>Total size for L2B_Rayleigh_Wind_QC in bytes:</b>				<b>22</b>

- end of table -

Table 48: Valid values for the extinction\_method field of the L2B.-Rayleigh\_Wind\_QC L2B/L2C Product Confidence Data L2B\_obsRayleigh\_Bin\_QC structure

Numerical value	Name	Description
0	Extinction_Meth_Undefined	Undefined.
1	Extinction_Not_Available	Not available.
2	Extinction_From_NWP_Comp	Using NWP information as specified in the ATBD [RD7]
...		

- end of table -

Table 49: Valid values for the Scattering\_Ratio\_method field of the L2B\_Rayleigh\_Wind\_QC L2B/L2C Product Confidence Data L2B\_obsRayleigh\_Bin\_QC structure

Numerical value	Name	Description
0	Scat_Ratio_Meth_Undefined	Undefined.
1	Scat_Ratio_Meth_UseAverage	Computed by averaging the measurement values used to construct this wind result
...		

- end of table -

#### 4.3.8 Mie HLOS wind Profiles MDS

The content of the DSR for the Mie wind Measurement Data Set (MDS) is detailed in Table 50.

Table 50: L2B/L2C Mie HLOSwind Data Set MDSR Content Description

Tag Name	Description/Comment	Unit	Type	Size (binary)
wind_result_id	unique L2B Mie wind result identification number for this L2B file		IntAul	4
Start_of_Obs_DateTime	Date and time of the first measurement used to compose the accumulated signals used to retrieve this wind result	UTC	DateTime	12
WindResult	structure containing the wind retrieval result associated to the current Mie accumulation for a given group and classification. See Table 51.		structure	13
Spare			Spare	5
<b>Total size for L2B/L2C Mie wind DSR in bytes:</b>				<b>34</b>

- end of table -

Table 51: L2B/L2C Mie HLOSwind Data List\_of\_Mie\_Height\_Bin.-  
 Winds Result Content Description

Tag Name	Description/Comment	Unit	Type	Size (binary)
which_range_bin	stores the range bin number this wind result belongs to		IntAuc	1
observation_type	remember if this was a cloud or no-cloud profile (or any other type we define). Possible codes are defined in Table 52		IntAuc	1
Validity_Flag	Validity flag (1 or TRUE = valid, 0 or FALSE = invalid) attached to the reported wind velocity. Details on the reasons why a result is invalid can be found in the l2b_mie_wind_pcd.-ads dataset. (See section 4.3.6)		Boolean	1
Mie_Wind_Velocity	Wind velocity given in cm/s and rounded to the nearest integer.	cm/s	IntAs	2
Integration_Length	Integration length for the reported Mie wind.	m	IntAul	4
N_Meas_in_class	Number of measurements used to construct the accumulation used to derive the current Mie wind result		IntAus	2
Spare			Spare	2
<b>Total size for L2B/L2C Mie Wind Result in bytes:</b>				<b>13</b>

- end of table -

Table 52: Valid values for the observation\_type field

Numerical value	Name	Description
0	Obs_Type_Undefined	for initialisation purposes only
1	Obs_Type_cloudy_returns	indicates a profile or wind result classified as cloudy
2	Obs_Type_clear_returns	indicates a profile or wind result classified as clear

- end of table -

#### 4.3.9 Rayleigh HLOS wind Profiles MDS

The content of the DSR for the L2B/L2C Rayleigh Wind MDS is given in Table 53.

 Table 53: L2B/L2C Rayleigh HLOSwind Data Set MDSR Content  
 Description

Tag Name	Description/Comment	Unit	Type	Size (binary)
wind_result_id	unique L2B Rayleigh wind result identification number for this L2B file		IntAul	4
Start_of_Obs_DateTime	Date and time of the first measurement used to compose the accumulated signals used to retrieve this wind result	UTC	DateTime	12
WindResult	structure containing the wind retrieval result associated to the current Rayleigh accumulation for a given group and classification. See Table 54.		structure	29
Spare			Spare	5
<b>Total size for L2B/L2C Rayleigh Wind MDS in bytes:</b>				<b>50</b>

Continued on Next Page...

Tag Name	Description/Comment	Unit	Type	Size (binary)
----------	---------------------	------	------	---------------

- end of table -

Table 54: L2B/L2C Rayleigh HLOSwind result Data List\_of\_-  
 Rayleigh\_Height\_Bin\_Winds Content Description

Tag Name	Description/Comment	Unit	Type	Size (binary)
which_range_bin	stores the range bin number this wind result belongs to		IntAuc	1
observation_type	remember if this was a cloud or no-cloud profile (or any other type we define). Possible codes are defined in Table 52.		IntAuc	1
Validity_Flag	Validity flag (1 or TRUE = valid, 0 or FALSE = invalid) attached to the reported wind velocity. Details on the reasons why a result is invalid can be found in the l2b_rayleigh_wind_pcd_ads dataset. (See section 4.3.7)		Boolean	1
Rayleigh_Wind_Velocity	Wind velocity given in cm/s and rounded to the nearest integer.	cm/s	IntAs	2
Rayleigh_Wind_to_- Pressure	First-order derivative of the HLOS wind with respect to the pressure inside the sensing volume. This parameter may be used to correct the reported HLOS wind from pressure modifications brought by the assimilation.	10-6 m/s/ Pa	IntAs	2
Rayleigh_Wind_to_- Temperature	First-order derivative of the HLOS wind with respect to the temperature inside the sensing volume. This parameter may be used to correct the reported HLOS wind from temperature modifications brought by the assimilation.	cm/ s/K	IntAs	2
Rayleigh_Wind_to_- Backscatter_Ratio	First-order derivative of the HLOS wind with respect to the backscattering ratio inside the sensing volume. This parameter may be used to correct the reported HLOS wind if the reference backscatter ratio is modified.	cm/s	IntAs	2
Reference_Pressure	Reference pressure used for inverting the Rayleigh response into an HLOS wind. This pressure information is taken from the numerical weather prediction model.	Pa	IntAul	4
Reference_Temperature	Reference temperature used for inverting the Rayleigh response into an HLOS wind. This temperature information is taken from the numerical weather prediction model.	10-2 K	IntAus	2
Reference_Backscatter_ Ratio	Reference backscatter ratio used for inverting the Rayleigh response measured by the lidar.	10-6	IntAul	4
Integration_Length	Integration length for the reported Rayleigh wind.	m	IntAul	4
N_Meas_in_class	Number of measurements used to construct the accumulation used to derive the current Rayleigh wind result		IntAus	2
Spare			Spare	2
<b>Total size for L2B/L2C Rayleigh Wind Result in bytes:</b>				<b>29</b>

- end of table -

#### 4.3.10 L2B Wind Profile MDS

The content of the DSR for the L2B/L2C Wind profile MDS is given in Table 55.

Table 55: L2B/L2C Wind Profile MDS Content Description

Tag Name	Description/Comment	Unit	Type	Size (binary)
Start_of_Obs_DateTime	Date and time of the first measurement used to compose the accumulated signals pointed at by this wind profile MDS	UTC	DateTime	12
Profile_lat_start	start latitude of the set of wind retrieval results pointed at by this profile MDS	10-6 degN	IntA1	4
Profile_lat_average	average latitude of the set of wind retrieval results pointed at by this profile MDS	10-6 degN	IntA1	4
Profile_lat_stop	stop latitude of the set of wind retrieval results pointed at by this profile MDS	10-6 degN	IntA1	4
Profile_lon_start	start longitude of the set of wind retrieval results pointed at by this profile MDS	10-6 degE	IntA1	4
Profile_lon_average	average longitude of the set of wind retrieval results pointed at by this profile MDS	10-6 degE	IntA1	4
Profile_lon_stop	stop longitude of the set of wind retrieval results pointed at by this profile MDS	10-6 degE	IntA1	4
Profile_DateTime_Start	Date and time of the first measurement used to compose the accumulated signals pointed at by this wind profile MDS	UTC	DateTime	12
Profile_DateTime_-Average	Average date and time of the measurements used to compose the accumulated signals pointed at by this wind profile MDS	UTC	DateTime	12
Profile_DateTime_Stop	Date and time of the last measurement used to compose the accumulated signals pointed at by this wind profile MDS	UTC	DateTime	12
L2B_Wind_Profile	structure containing reference id numbers of wind retrieval results associated with the current profile for a given group and classification. See Table 56.		Structure	54
<b>Total size for L2B/L2C Wind Profile MDS in bytes:</b>				<b>126</b>

- end of table -

Table 56: L2B Wind Profile Content Description

Tag Name	Description/Comment	Unit	Type	Size (binary)
Channel	Switch indicating to which channel this profile refers. Possible values are listed in Table 57.		IntAuc	1
Obs_Type	remember if this was a cloud or no-cloud profile (or any other type we define). Possible codes are defined in See Table 52.		IntAuc	1
num_winds_in_profile	Number of wind results pointed at by this profile (both valid and invalid)		IntAuc	1
profile_id_number	unique L2B wind profile identification number for this L2B file		IntAus	2

Continued on Next Page...

Tag Name	Description/Comment	Unit	Type	Size (binary)
wind_result_id_number	A list of 24 wind id values referring to at most 24 individual wind results that are assigned to this profile. The reserved value of 0 is used to indicate no wind was assigned to the profile at that specific level.		list of 24 numbers of type IntAus	48
Spare			Spare	1
<b>Total size for L2B Wind Profile in bytes:</b>				<b>54</b>

- end of table -

Table 57: Valid values for the Channel field

Numerical value	Name	Description
0	Undefined_Channel	for initialisation purposes only
1	Mie_Channel	indicates a Mie profile
2	Rayleigh_Channel	indicates a Rayleigh profile

- end of table -

#### 4.3.11 L2C Mie Assimilation Product Confidence Data (PCD) ADS

This dataset is only present in L2C products. The content of the DSR for the L2C Assimilation Product Confidence Annotation Data Set (MDS) is detailed in Table 58.

Table 58: L2C Mie Assimilation Product Confidence Data ADSR Content Description

Tag Name	Description/Comment	Unit	Type	Size (binary)
wind_result_id	unique L2B wind result identification number for this L2C file		IntAul	4
L2C_Mie_Quality_Params	Structure containing all the L2C-derived quality information related to the current Mie wind result for the current accumulation (i.e. error estimates, validity flags...). See Table 59		structure	131
Spare			Spare	20
<b>Total size for L2C Assimilation PCD ADS in bytes:</b>				<b>155</b>

- end of table -

Table 59: L2C Assimilation Product Confidence Data List\_of\_L2C\_Mie\_Quality\_Params Content Description

Tag Name	Description/Comment	Unit	Type	Size (binary)
Obs.Type	remember if this was a cloud or no-cloud profile (or any other type we define). Possible codes are defined in See Table 52.		IntAuc	1
Spare			Spare	36
L2C_Mie_Height_Bin_Quality_Params	Structure containing all the information pertaining to the current Mie wind result (see Table 60).		Structure	94
<b>Total size for L2C Mie Quality Params in bytes:</b>				<b>131</b>

Continued on Next Page...

Tag Name	Description/Comment	Unit	Type	Size (binary)
----------	---------------------	------	------	---------------

- end of table -

Table 60: L2C Mie Height Bin Quality Params Content Description

Tag Name	Description/Comment	Unit	Type	Size (binary)
L2B_Mie_Obs_Screening	Structure describing QC parameters resulting from screening of L2B Mie wind result (see Table 61)		Structure	18
Assimilation_Model_PCD	Structure describing product confidence for assimilation model parameters associated with the current Mie wind result (see Table 63)		Structure	66
Spare			Spare	10
<b>Total size for L2C Mie Bin Quality Params in bytes:</b>				<b>94</b>

- end of table -

Table 61: L2C Mie Assimilation Product Confidence Data L2B\_Mie\_Obs\_Screening Content Description

Tag Name	Description/Comment	Unit	Type	Size (binary)
L2B_Mie_Obs_QC	A code describing a problem which prevents use of this Mie wind result (see Table 62 for a list of valid values).		IntAuc	1
L2B_Mie_Obs_QC_Flags	Flags describing problems which prevent using this Mie wind result Bit 1 : TBD Bit 2 : TBD ... Bit 8 : TBD		IntAuc	1
Spare			Spare	16
<b>Total size for L2C Mie Obs Screening in bytes:</b>				<b>18</b>

- end of table -

Table 62: Valid values for the L2B\_Mie\_Obs\_QC field of the L2C Product Confidence Data L2B\_Mie\_Obs\_Screening structure

Numerical value	Name	Description
0	L2B_Mie_Obs_OK	L2B Mie observation contents seem OK
1		
2		
3		

- end of table -



Table 63: L2C Assimilation Product Confidence Data L2C\_Assimilation\_Model\_PCD Content Description

Tag Name	Description/Comment	Unit	Type	Size (binary)
HLOS_observation_errors	Structure containing error estimates assumed during L2C processing, for the current L2B HLOS observation. See Table 64		Structure	28
Background_hlos	HLOS from the assimilation model background field given in cm/s and rounded to the nearest integer.	cm/s	IntAs	2
Background_hlos_error	Error in cm/s for Background_hlos.	cm/s	IntAus	2
L2B_hlos_reliability	An L2C-derived measure of the reliability of the current L2B HLOS observation		FAdoxy	8
Analysis_hlos	HLOS from the assimilation mode 1 analysis field given in cm/s and rounded to the nearest integer.	cm/s	IntAs	2
Zonal_wind_background_error	Error in cm/s for zonal wind from the assimilation model background.	cm/s	IntAus	2
Meridional_wind_background_error	Error in cm/s for meridional wind from the assimilation model background.	cm/s	IntAus	2
Spare			Spare	20
<b>Total size for Assimilation Model PCD in bytes:</b>				<b>66</b>

- end of table -

Table 64: L2C Assimilation Product Confidence Data HLOS\_Observation\_Errors Content Description

Tag Name	Description/Comment	Unit	Type	Size (binary)
persistence_error	Persistence error.	cm/s	IntAus	2
representativity_error	Representativity error.	cm/s	IntAus	2
final_error	Final error	cm/s	IntAus	2
estimated_obs_bias	Estimated bias for the current L2B HLOS wind result.	cm/s	IntAs	2
Spare			Spare	20
<b>Total size for HLOS Observation Errors in bytes:</b>				<b>28</b>

- end of table -

#### 4.3.12 L2C Rayleigh Assimilation Product Confidence Data (PCD) ADS

This dataset is only present in L2C products. The content of the DSR for the L2C Rayleigh Assimilation Product Confidence Annotation Data Set (MDS) is detailed in Table 65.

Table 65: L2C Rayleigh Assimilation Product Confidence Data ADSR Content Description

Tag Name	Description/Comment	Unit	Type	Size (binary)
wind_result_id	unique L2B wind result identification number for this L2C file		IntAul	4

Continued on Next Page...

Tag Name	Description/Comment	Unit	Type	Size (binary)
L2C_Rayleigh_-Quality_Params	Structure containing all the L2C-derived quality information related to the current Rayleigh HLOS wind result for the current accumulation (i.e. error estimates, validity flags...). See Table 66		structure	131
Spare			Spare	20
<b>Total size for L2C Assimilation PCD ADS in bytes:</b>				<b>155</b>

- end of table -

Table 66: L2C Assimilation Product Confidence Data List\_of\_-L2C\_Rayleigh\_Quality\_Params Content Description

Tag Name	Description/Comment	Unit	Type	Size (binary)
Obs.Type	remember if this was a cloud or no-cloud profile (or any other type we define). Possible codes are defined in Table 52.		IntAuc	1
Spare			Spare	36
L2C_Rayleigh_Height_-Bin_Quality_Params	Structure containing all the information pertaining to the current Rayleigh wind result (see Table 67).		Structure	94
<b>Total size for L2C Rayleigh Quality Params in bytes:</b>				<b>131</b>

- end of table -

Table 67: L2C Rayleigh Height Bin Quality Params Content Description

Tag Name	Description/Comment	Unit	Type	Size (binary)
L2B_Rayleigh_Obs_-Screening	Structure describing QC parameters resulting from screening of L2B Rayleigh wind result (see Table 68)		Structure	18
Assimilation_Model_-PCD	Structure describing product confidence for assimilation model parameters associated with the current Rayleigh wind result (see Table 63)		Structure	66
Spare			Spare	10
<b>Total size for L2C Rayleigh Bin Quality Params in bytes:</b>				<b>94</b>

- end of table -

Table 68: L2C Rayleigh Assimilation Product Confidence Data L2B\_Rayleigh\_Obs\_Screening Content Description

Tag Name	Description/Comment	Unit	Type	Size (binary)
L2B_Rayleigh_Obs_QC	A code describing a problem which prevents use of this Rayleigh wind result (see Table 69 for a list of valid values).		IntAuc	1

Continued on Next Page...

Tag Name	Description/Comment	Unit	Type	Size (binary)
L2B_Rayleigh_Obs_-QC_Flags	Flags describing problems which prevent using this Rayleigh wind result Bit 1 : TBD Bit 2 : TBD ... Bit 8 : TBD		IntAuc	1
Spare			Spare	16
<b>Total size for L2C Rayleigh Obs Screening in bytes:</b>				<b>18</b>

- end of table -

Table 69: Valid values for the L2B\_Rayleigh\_Obs\_QC field of the L2C Product Confidence Data L2B\_Rayleigh\_Obs\_Screening structure

Numerical value	Name	Description
0	L2B_Rayleigh_Obs_OK	L2B Rayleigh observation contents seem OK
1		
2		
3		

- end of table -

#### 4.3.13 Mie Vector-Wind Profiles MDS

This dataset is present only in L2C products. The content of the DSR for the L2C Mie Vector-wind Measurement Data Set (MDS) is detailed in Table 70.

Table 70: L2C Mie Vector-Wind Data Set MDSR Content Description

Tag Name	Description/Comment	Unit	Type	Size (binary)
wind_result_id	unique L2B/L2C wind result identification number for this L2C file		IntAul	4
Start_of_Obs_DateTime	Start date and time of the first measurement included in the present DSR. This is the same time as in the Geolocation ADS repeated here for cross-checking purposes.	UTC	DateTime	12
Height_Bin_VecWind	Data structure giving background and analysis vector results. See table 71		structure	29
<b>Total size for L2C Mie Vector-Wind MDSR in bytes:</b>				<b>45</b>

- end of table -

Table 71: L2C Mie Vector-Wind Bin Data List\_of\_Mie\_Height\_-Bin\_VecWinds and Rayleigh Wind Data List\_of\_Rayleigh\_Height\_-Bin\_VecWinds Content Description

Tag Name	Description/Comment	Unit	Type	Size (binary)
Validity_Flag	Validity flag (1 or TRUE = valid, 0 or FALSE = invalid) attached to the reported wind height bin velocity.		Boolean	1

Continued on Next Page...

Tag Name	Description/Comment	Unit	Type	Size (binary)
Background_Zonal_Wind_Velocity	Background zonal wind velocity given in cm/s and rounded to the nearest integer.	cm/s	IntAs	2
Background_Meridional_Wind_Velocity	Background meridional wind velocity given in cm/s and rounded to the nearest integer.	cm/s	IntAs	2
Analysis_Zonal_Wind_Velocity	Analysis zonal wind velocity given in cm/s and rounded to the nearest integer.	cm/s	IntAs	2
Analysis_Meridional_Wind_Velocity	Analysis meridional wind velocity given in cm/s and rounded to the nearest integer.	cm/s	IntAs	2
Spare			Spare	20
<b>Total size for L2C Height Bin VecWind in bytes:</b>				<b>29</b>

- end of table -

#### 4.3.14 Rayleigh Vector-Wind Profiles MDS

This dataset is present only in L2C products. The content of the DSR for the L2C Rayleigh Vector-wind Measurement Data Set (MDS) is detailed in Table 72.

Table 72: L2C Rayleigh Vector-Wind Data Set MDSR Content Description

Tag Name	Description/Comment	Unit	Type	Size (binary)
wind_result_id	unique L2B/L2C wind result identification number for this L2C file		IntAul	4
Start_of_Obs_DateTime	Start date and time of the first measurement included in the present DSR. This is the same time as in the Geolocation ADS repeated here for cross-checking purposes.	UTC	DateTime	12
Height_Bin_VecWind	Data structure giving background and analysis vector results. See table 71		structure	29
<b>Total size for L2C Mie Vector-Wind MDSR in bytes:</b>				<b>45</b>

- end of table -

#### 4.4 File Size

The overall organization and size is summarized in Table 74.

It is assumed that the L1B file had 400 BRCs, and uses 30 measurements per BRC, and that we use an AuxMet file holding 2 profiles per L1B BRC (one nadir and one off-nadir). Subsequently it is assumed that the L2BP grouping runs in classic mode so defines 1 group for each L1B BRC. It is assumed that for each group the L2BP produces for the Mie channel a cloudy profile holding wind 5 results and a clear profile holding also 5 wind results. Furthermore it is assumed that for each group the L2BP produces for the Rayleigh channel a cloudy profile holding 5 Rayleigh wind results and a clear profile holding 24 Rayleigh wind results. In this case the total sizes of the L2B/L2C product DataBlock components are:

Table 73: Total sizes of the L2B/L2C product DataBlock components

dataset name	L2B Size	Unit	L2C Size	Unit
MPH	1 247	bytes	1 247	bytes
SPH	6748	bytes	8861	bytes
Measurement Map ADS	3 696 000	bytes	3 696 000	bytes
Mie Grouping ADS	12 000	bytes	12 000	bytes
Rayleigh Grouping ADS	12 000	bytes	12 000	bytes

Continued on Next Page...

dataset name	L2B Size	Unit	L2C Size	Unit
Mie Geolocation ADS	524 000	bytes	524 000	bytes
Rayleigh Geolocation ADS	1 519 600	bytes	1 519 600	bytes
AMD Product Confid Data ADS	43 200	bytes	43 200	bytes
Meas Product Confid Data ADS	13 788 000	bytes	13 788 000	bytes
Mie Wind Prod Conf Data ADS	548 000	bytes	548 000	bytes
Rayl Wind Prod Conf Data ADS	672 800	bytes	672 800	bytes
Mie wind MDS	136 000	bytes	136 000	bytes
Rayleigh wind MDS	580 000	bytes	580 000	bytes
Mie Profile MDS	100 800	bytes	100 800	bytes
Rayleigh Profile MDS	100 800	bytes	100 800	bytes
L2B Total	21 741 195	bytes	-	bytes
Mie Assimilation PCD ADS	-	bytes	620 000	bytes
Rayleigh Assimilation PCD ADS	-	bytes	1 798 000	bytes
Mie Vector-Wind MDS	-	bytes	180 000	bytes
Rayleigh Vector-Wind MDS	-	bytes	522 000	bytes
L2C Total	-	bytes	24 861 195	bytes

- end of table -

Table 74: Overall organization of L2B output and input products. The attached datasets are L2B output, referenced datasets are L2B input. Daily sizes in the last column based on 16 orbits / day.

DS name	Content description	Type	Format	Size / day (Mb)
Meas Map ADS	Data set containing the mapping between L1B and L2B data, needed to find the exact L1B measurements that have been used in each L2B accumulation result.	Attached	Binary	59
Mie Grouping ADS	Data set containing the measurement grouping for the Mie channel, which controls which L1B measurements are considered for accumulation into a single wind result during the classification phase	Attached	Binary	0.2
Rayleigh Grouping ADS	Data set containing the measurement grouping for the Rayleigh channel, which controls which L1B measurements are considered for accumulation into a single wind result during the classification phase	Attached	Binary	0.2
Mie Geolocation ADS	Data set containing the space and time location of all L2B/C Mie wind results, the direction of the line-of-sight, the satellite velocity and the intersection point with the DEM	Attached	Binary	8

Continued on Next Page...

DS name	Content description	Type	Format	Size per day (Mb)
Rayleigh Geolocation ADS	Data set containing the space and time location of all L2B/C Rayleigh wind results, the direction of the line-of sight, the satellite velocity and the intersection point with the DEM	Attached	Binary	24
AMD PCD ADS	Data set containing the quality control results for the AMD input profiles used by the L2BP	Attached	Binary	0.6
Meas PCD ADS	Data set containing the quality control results for the L1B measurement input data used by the L2BP	Attached	Binary	221
Mie Wind PCD ADS	Data set containing the quality control and product confidence indicators for the L2B Mie wind results	Attached	Binary	9
Rayleigh Wind PCD ADS	Data set containing the quality control and product confidence indicators for the L2B Rayleigh wind results	Attached	Binary	11
Mie Wind MDS	Measurement data set containing Mie HLOS wind retrieval results	Attached	Binary	2
Rayleigh Wind MDS	Measurement data set containing Rayleigh HLOS wind retrieval results corrected from pressure, temperature and Mie contamination effects + sensitivity coefficients to pressure and temperature	Attached	Binary	9
Mie Profile MDS	Data set containing profile definitions of Mie wind retrieval results	Attached	Binary	1.6
Rayleigh Profile MDS	Data set containing profile definitions of Rayleigh wind retrieval results	Attached	Binary	1.6
L2B DataSets Total				348
Mie Assimilation PCD ADS	Data set containing the L2C-related assimilation product confidence indicators for the L2C Mie channel products	Attached	Binary	10
Rayleigh Assimilation PCD ADS	Data set containing the L2C-related assimilation product confidence indicators for the L2C Rayleigh channel products	Attached	Binary	29
Mie Vector-Wind MDS	Measurement data set containing Mie vector wind observations	Attached	Binary	3

Continued on Next Page...

DS name	Content description	Type	Format	Size per day (Mb)
Rayleigh Vector-Wind MDS	Measurement data set containing Rayleigh vector wind observations	Attached	Binary	8
L2C DataSets Total				398
Aux Met MDS	Measurement data set that contains all the meteorological data needed for re-processing L1B data at the PDS. These data characterize the thermodynamic state of the atmosphere inside the atmospheric volumes sensed by the lidar. They are obtained from a numerical weather prediction model (for example during a meteorological analysis). At ECMWF, one file is produced every assimilation cycle, that is, every 12 hours	Referenced	Binary	13 upto 106
Aux L2B Param	Data set containing L2B processor settings. Only updated when a new L2BP software versions is released.	Referenced	XML	0.02
Aux RBC	Data set containing the Rayleigh Brillouin look-up tables Note that the filesize scales with the frequency stepping chosen during generation of this calibration file. It is foreseen that this file will be updated approximately once per week	Referenced	Binary	29
Aux Cal	Data set containing auxiliary calibration data that characterises the optical system including the spectrometers and the full optical path. Note that use of this file is not yet implemented in the L2BP software, but we reserve the possibility to add additional algorithms in future updates that will use it. The update frequency of this filetype is not yet known	Referenced	Binary	20

Continued on Next Page...

DS name	Content description	Type	Format	Size per day (Mb)
Aux Clim	Data set containing auxiliary climatological data that characterises the expected relation between aerosol extinction and backscatter, as a function of location, altitude and time of year. Note that use of this file is not yet implemented in the L2BP software, but we reserve the possibility to add additional algorithms in future updates that will use it. The update frequency of this filetype is not yet known	Referenced	Binary	0.2

- end of table -

The Aux Met DS is based on 60 model layers per profile, as employed in current test versions. Future versions will use 91 layers. For sizing purposes at the time Aeolus is in orbit, 120 layers could be realistic, and so the DBL size should be scaled proportionately (i.e. doubled).



## 5 Input Auxiliary Files

### 5.1 Auxiliary Meteorological Data Set

Auxiliary Meteorological Data (AMD) are an input to the L2B processor. They contain all the meteorological parameters that are needed for running the L2B processor in re-processing mode, e.g. at the Core PDS. They are stored in a separate, independent file referenced in the header section of the main L2B product file.

AMD are a product of Aeolus support processing which will take place at the L2-PF (ECMWF) and potentially at other sites such as national weather services. The AMD products created at ECMWF, and subsequently available from the LTA, typically cover the time period of one assimilation window. At ECMWF, these windows are either 9 → 21 UTC or 21 → 9 UTC the next day.

Each file contains four data sets:

- GeoADS#1: contains the geolocation information for all the meteorological parameters necessary for (re-)processing off-nadir L1B measurements.
- GeoADS#2: contains the geolocation information for all the meteorological parameters necessary for (re-)processing nadir L1B measurements.
- MetDS#1: contains the meteorological parameters for off-nadir L1B measurements. GeoADS#1 and MetDS#1 contain the same number of records.
- MetDS#2: contains the meteorological parameters for nadir L1B measurements. GeoADS#2 and MetDS#2 contain the same number of records.

For further details on the use of Auxiliary Meteorological Data, see [RD1]. Details of their use in L2A processing and L1 calibration processing are beyond the scope of L2B documents.

The geolocation datasets GeoADS#1 and GeoADS#2 specify the horizontal location (latitude and longitude) of each profile in the corresponding MetDS. Each DSR in MetDS#1 and MetDS#2 contains details of the vertical coordinate and vertical profiles of meteorological parameters. The vertical profiles of auxiliary met data are given as a function of the pressure for the vertical coordinate. The pressure layers are those of the NWP model. To allow for an easy conversion of pressure layers into altitudes, vertical profiles of geopotential heights are included in the data set records.

#### 5.1.1 Product Structure

The AMD product conforms to the product structure defined in Section 3.4.

#### 5.1.2 File Name

The Auxiliary Meteorological Data file name has the format defined in Section 3.1:

AE.CCCC\_AUX\_MET.<instance.ID>.EEE

where <instance.ID> is defined in section 3.1.

After filling the instance string with its definition the file name has this format:

AE.CCCC\_AUX\_MET\_ss\_yyyymmddThhmmss\_yyyymmddThhmmss\_vvvv.EEE

The extension EEE is HDR for the header and DBL for the data block. That is, the AMD product consists of two files:

- A header containing a Fixed Header, MPH, and SPH with DSDs. The header is in XML format and has extension EEE='HDR'.
- A datablock containing a copy of MPH and SPH in KVT format followed by the DataSets in binary format. The data block has the file extension EEE='DBL'.

Consistent with [AD5]. AMD created at ECMWF will set CCCC='OPER' and ss='12'. The latter setting is used to indicate that AMD can be used in Level 1 (calibration) processing and Level 2A/2B processing. There is scope for others, notably Met Centres other than ECMWF, to generate alternative AMD distinguished by different settings for 'CCCC'.

### 5.1.3 File Structure

The Header File contains a Fixed Header and a Variable Header. The Variable Header contains the MPH as described in section 3.4 and the AMD SPH. The AMD SPH is described in Section 5.1.4 below. The Data Sets in the datablock are described in sections 5.1.7 and 5.1.8.

**Note:** a common MPH is retained for all auxiliary data files, but some parameters may in future be set to a "missing value" (GSDR RID 166).

### 5.1.4 Specific Product Header

The Specific Product Header of the L2B AMD is detailed in Table 75.

Table 75: L2B Auxiliary Meteorological Data Specific Product Header Content Description

Tag Name	Content Description	Unit	Type	Size (KVT)			Size (XML)		
Specific_Product_-Header	Root tag (XML format only).		Structure	N/A			26	0	27
Sph_Descriptor	Specific Product Header descriptor: ASCII string describing the product		String	16	28	2	16	28	18
Spare_1			Spare	40	0	1	10	0	11
Ref_NWP_Suite	Reference of the NWP suite that was used to produce the met data.		String	15	20	2	15	20	17
Fcst_Initial_Time	Forecast initial date and time	UTC	DateTime	19	27	2	19	30	21
Model_Timestep	Model integration timestep	s	IntAl	15	11	4	16	11	18
Model_Grid_Type	Model grid type. 'GF' or 'GR' indicates full or reduced Gaussian grid, 'SH' indicates spherical harmonics 'LL' indicates a regular grid with fixed latitude and longitude spacing		Enum	16	2	1	17	2	19
Model_Resol_Par1	Model resolution parameter 1. 'SH' or 'GF' or 'GR': truncature ; 'LL': latitude spacing		IntAs	17	6	1	18	6	20
Model_Resol_Par2	Model resolution parameter 2. 'SP' or 'GF' or 'GR': stretching, if any; 0 otherwise ; 'LL': longitude spacing		IntAs	17	6	1	18	6	20
Num_of_Model_Layers	Number of pressure layers for AMD profiles		IntAus	20	6	1	21	5	23
Num_Records_in_DS1	Total number of records in GeoADS#1 or MDS#1 (off-nadir met profiles).		IntAl	19	11	1	20	10	22
Num_Records_in_DS2	Total number of records in GeoADS#2 or MDS#2 (nadir met profiles).		IntAl	19	11	1	20	10	22
Num_Avail_L1B_Obs	Number of L1B observations that were available at the time the assimilation was started.		IntAl	18	11	1	19	10	21
Num_Missing_L1B_Obs	Number of L1B observations that were missing at the time the assimilation was started.		IntAl	20	11	1	21	10	23
Num_Computed_Locations	Number of profile locations computed from predicted orbit tracks to compensate for missing L1B observations.		IntAl	23	11	1	24	10	26
Spare_2			Spare	40	0	1	10	0	11

Continued on Next Page...

Tag Name	Content Description	Unit	Type	Size (KVT)	Size (XML)
Num_Input_Files	Number of input files that were used for obtaining locations for computation of AMD. Input files are either L1B (WVM) files or predicted orbit files. This field is unlikely to exceed 10.		IntAus	16 6 1	17 5 19
Num_Files_Predict_Orbit	Number of predicted orbit files that were used for computing expected L1B profile locations and corresponding AMD. If no L1B data was missing, this field is zero. This field must not exceed Num_Input_Files.		IntAus	24 6 1	25 5 27
Spare_3			Spare	40 0 1	10 0 11
List_of_Dsds	See Table 76 for a description. The size estimates given here are for Num_Input_Files=10, which is unlikely to be exceeded.			4032	5038
<b>Total size for KVT and XML SPH in bytes:</b>				<b>4623</b>	<b>5924</b>

- end of table -

### 5.1.5 Data Set Descriptors

The Data Sets listed in Table 76 appear in Aeolus AMD products, each described by a DSD in the SPH.

Table 76: Auxiliary Meteorological Data Sets

DSD Number	Name	Description / Comment	DataSet Type	Update Frequency
1	GeoADS#1	DSD for Geolocation & AOCS data (off-nadir, one DSR / profile). See Table 77 for a description.	A	1 DSR per AuxMet profile
2	GeoADS#2	DSD for Geolocation & AOCS data (nadir, one DSR / profile). See Table 77 for a description.	A	1 DSR per AuxMet profile
3	MetDS#1	DSD for Meteorological Data (off-nadir, for re-processing etc, one DSR / profile). See Table 78 for a description.	A	1 DSR per AuxMet profile
4	MetDS#2	DSD for Meteorological Data (nadir, one DSR / profile). See Table 78 for a description.	A	1 DSR per AuxMet profile
5 to (4+Num-Input_Files)	Input_DS#1 to Input_DS#Num_Input_Files	DSD for each input file used for obtaining locations for computation of AMD. The first (Num_Input_Files-Num_Files_Predict_Orbit) DSDs correspond to actual L1B product files, the last Num_Files_Predict_Orbit DSDs correspond to predicted orbit files.	R	No DS

- end of table -

A description of the "Data Set Type" can be found in Table 12 described in section 3.4.3 on page 26. Note that only the first four datasets are of type "A", or "Attached", meaning that they are included in the AMD datablock file. Their content is described in Sections 5.1.7 and 5.1.8.

### 5.1.6 Data Sets

The following sections describe the datasets defined for the Auxiliary Meteorological data.

### 5.1.7 GEOLOCATION ADS

The Geolocation Annotation Data Sets (GeoADS) #1 and #2 are described in Table 77.

Table 77: L2B Auxiliary Meteorological Data Geolocation Data Set #1 and #2 ADSR Content Description. Note that AMD\_zg shall be removed following confirmation that geoid height will be supplied in L1B data.

Tag Name	Description/Comment	Unit	Type	Size (binary)
AMD_DateTime	Date and time	UTC	DateTime	12
AMD_Latitude	Latitude of the whole profile.	10-6 degN	IntA1	4
AMD_Longitude	Longitude of the whole profile.	10-6 degE	IntA1	4
AMD_zg	Geoid height above WGS84 reference ellipsoid	cm	IntA1	4
<b>Total size for AMD Geolocation ADS in bytes:</b>				<b>24</b>

- end of table -

### 5.1.8 METEOROLOGICAL MDS

The Meteorological Data Sets (MetDS) #1 and #2 are described in Table 78.

The only parameters of the Meteorological Data Set to be used in baseline L2B processing are those related to Rayleigh-Brillouin corrections, i.e. parameters relating to temperature, pressure, and geopotential height. The other parameters may be used in optional extensions to baseline L2B processing, and in L2A processing.

Table 78: L2B Auxiliary Meteorological Data Meteorological Set #1 and #2 MDSR Content Description

Tag Name	Description/Comment	Unit	Type	Size (binary)
Spare_1			Spare	2
AMD_us	East-West wind component at the surface (>0 to East). This information can be used for qualifying Mie wind in ground echo-height-bins.	cm/s	IntAs	2
AMD_vs	North-South wind component at the surface (>0 to North). This information can be used for qualifying Mie wind in ground echo-height-bins.	cm/s	IntAs	2
AMD_ps	Surface pressure. May be used for detecting severe events like tropical cyclones.	Pa	IntAul	4
AMD_err_ps	Std error on AMD_ps	Pa	FAdoxy	8
AMD_zs	Geopotential height at pressure AMD_ps. Gives the altitude of the surface according to the weather model.	cm	IntA1	4
Spare_2			Spare	2
List_of_Profile_Data	List of Num_of_Model_Layers substructures each containing the meteorological data constituting the vertical profile. Each substructure corresponds to one model layer (see Table 79). (the size of this list is calculated by assuming 60 model layers)		list of structures	4260
Spare_3			Spare	2

Continued on Next Page...

Tag Name	Description/Comment	Unit	Type	Size (binary)
<b>Total size for AMD Meteo MDS in bytes:</b>				<b>4286</b>

- end of table -

Table 79: L2B Auxiliary Meteorological Data List\_of\_Profile.Data  
 Content Descriptioionor

Tag Name	Description/Comment	Unit	Type	Size (binary)
AMD_Validity_Flag	"0" for a valid level with a complete set of AMD data with all parameters extracted from the NWP model ; "-1" for an incomplete level containing at least valid temperature, valid pressures, and valid heights ; "-2" otherwise. Other flags could be added later		IntAc	1
AMD_pbase	Pressure at the bottom of the model layer	Pa	IntAul	4
AMD_ptop	Pressure at the top of the model layer	Pa	IntAul	4
AMD_pnom	Nominal pressure within the model layer, can differ from (AMD_pbase+AMD_ptop)/2.	Pa	IntAul	4
AMD_zbase	Geopotential height at pressure AMD_pbase	cm	IntAl	4
AMD_ztop	Geopotential height at pressure AMD_ptop	cm	IntAl	4
AMD_znom	Geopotential height at pressure AMD_pnom	cm	IntAl	4
AMD_T	Temperature at pressure AMD_pnom	10 <sup>-2</sup> K	IntAus	2
AMD_err_T	Std error on AMD_T	10 <sup>-2</sup> K	IntAus	2
AMD_u	East-West wind velocity (>0 to East)	cm/s	IntAs	2
AMD_v	North-South wind velocity (>0 to North)	cm/s	IntAs	2
Spare_1			Spare	4
AMD_rh	Relative humidity at pressure AMD_pnom	%	IntAuc	1
AMD_err_rh	Std error on AMD_rh	%	FAdoxy	8
AMD_q	Specific humidity at pressure AMD_pnom	kg/kg	FAdoxy	8
AMD_cc	Cloud cover at pressure AMD_pnom	%	IntAuc	1
AMD_clwc	Cloud liquid water content at pressure AMD_pnom	kg/kg	FAdoxy	8
AMD_ciwc	Cloud ice water content at pressure AMD_pnom	kg/kg	FAdoxy	8
<b>Total size for AMD Meteo Profiles in bytes:</b>				<b>71</b>

- end of table -

### 5.1.9 File Size

(NOTE: this section is still to be updated to continuous mode)

The total size for Auxiliary Meteorological Data products is summarized in Table 80 on the basis of a number of model pressure levels equal to 60. Two extremes of size are considered. The best, i.e. smallest size, option (left column) is when all L1B data are available. Then GeoADS#2 and MDS#2 are empty and there are 200 records per orbit (15 orbits per day). The worst, i.e. largest size, option is when no L1B data are available. Then both nadir and off-nadir data sets must be filled, and there are 800 records in each dataset per orbit.

Table 80: Size of L2B Auxiliary Meteorological Data file. One file is produced every time an assimilation is run, that is, every 12 hours.

	Section	Format	Size (best case) per file	Size (worst case) per file
<b>Header File</b>	FH	XML		699
	MPH	XML		1582
	SPH	XML		5924
<b>Total size in bytes for HDR file</b>				<b>8205</b>
<b>Data Block</b>	MPH	KVT		1247
	SPH	KVT		4623
	GeoADS#1	Binary	72000	288000
	GeoADS#2	Binary	0	288000
	MDS#1	Binary	12858000	51432000
	MDS#2	Binary	0	51432000
	<b>Total size in bytes for DBL file</b>			<b>12935870</b>
<b>Total size for HDR+DBL in Mb</b>			<b>12.3</b>	<b>98.7</b>

- end of table -

Note that the Aux Met DS size estimate is based on 60 model layers per profile, as employed in current test versions. Future versions will use 91 layers. For sizing purposes at the time Aeolus is in orbit, 120 layers could be realistic, and so the DBL size should be scaled proportionately (i.e. doubled).

## 5.2 Rayleigh-Brillouin Correction (RBC) tables

(section deleted) The description of this dataset has been moved to a separate document (see [\[RD8\]](#)).

## 5.3 Auxiliary Climatology Dataset

Auxiliary Climatology look-up tables are contained in the AUX\_CLM\_L2 data product. The initial tables are to be generated by KNMI. These tables will be updated as more spaceborne lidar measurements are collected. They contain values for the extinction-to-backscatter ratio for aerosols as function of location and time of the year.

This input to the L2B processor may also be suitable as an input to L2A processing. Hence a filetype of the form AUX\_CLM\_2x could be appropriate. Such a file would be updated infrequently, perhaps once per year. A candidate dataset under consideration consists of atmospheric optical properties. An indication of the possible file size is given on the following basis of data from the GLAS instrument:

Optical parameters: particle extinction-to-backscatter ratio, associated error quantifier  
 Vertical layers: 10  
 Horizontal grid: 180 x 90 (2 degrees by 2 degrees)  
 Temporal resolution: 4 (once per season)  
 Datatype: FAdoxy (8 bytes within a binary DBL)  
 Total: 10.5 MB (Example 1)

Depending on progress with newer satellite data, e.g. CALIPSO, a larger dataset could be envisaged:  
 Vertical layers: 30  
 Horizontal grid: 360 x 180 (1 degree by 1 degree)  
 Temporal resolution: 12 (once per month)  
 Datatype: FAdoxy (8 bytes within a binary DBL)  
 Total: 363 MB (Example 2)

However, since at first this file will be used mainly within the L2B processor for classification of the situation where only the FP channel is available, a much coarser resolution will be used for a first version of this file:

Vertical layers:	4
Horizontal grid:	36 x 18 (10 degrees by 10 degrees)
Temporal resolution:	4 (once per season)
Datatype:	IntA1 (4 bytes within a binary DBL)
Total:	192 kB (Example 3)

### 5.3.1 Product Structure

The Clim product conforms to the product structure defined in Section 3.4.

### 5.3.2 File Name

The Clim Data file name has the format defined in Section 3.1:

AE\_CCCC\_AUX\_CLM.L2\_yyyyymmddThhmmss\_yyyyymmddThhmmss\_vvvv.EEE

The extension EEE is HDR for the header and DBL for the data block. That is, the Clim product consists of two files:

- A header containing a Fixed Header, MPH, and SPH with DSDs. The header is in XML format and has extension EEE='HDR'.
- A datablock containing a copy of MPH and SPH in KVT format followed by the DataSets in binary format. The data block has the file extension EEE='DBL'.

### 5.3.3 File Structure

The Header File contains a Fixed Header and MPH as described in Section 3.4. The SPH is described in Section 5.3.4 below. The Data Sets in the datablock are described in Section ....

Note: a common MPH is retained for all auxiliary data files, but some parameters may in future be set to a "missing value" (GSDR RID 166).

Note that the chosen file organisation has a large flexibility in defining the grid on which the data is provided. For each season a different grid may be used. For each latitude band the longitude grid may be changed, to allow for example coarser resolution near the poles. For each (date, lat, lon) location a different altitude profile may be specified to allow adapting to a varying height of the PBL, troposphere, stratosphere boundaries, etc. On the other hand a simple regular grid is of course also possible, but for this case the file has some overhead due to multiple copies of the same start/end values (main contribution to this overhead is in StartAltitude and EndAltitude variables which fill about half the bytes of the file). For the envisaged use in the L2BP this is not expected to be a problem since the L2BP will use a coarse resolution with a file size of around 180 kB. When it becomes necessary to go to higher resolutions (with file sizes of several 100 MB) it may be desirable to have this flexibility to save storage space near the poles or in large uniform areas (like in the middle of the oceans).

### 5.3.4 Clim Specific Product Header

The Specific Product Header of the L2B Clim is detailed in Table 81.

Table 81: Aux Clim Specific Product Header Content Descriptor

Tag Name	Content Description	Unit	Type	Size (KVT)	Size (XML)
Specific_Product_Header	Root tag (XML format only).		Structure	N/A	26 0 27
Sph_Descriptor	Specific Product Header descriptor: ASCII string describing the product		String	16 28 2	15 28 17
Spare_1			Spare	40 0 1	9 0 11
AuxClim_Ref_Name	Reference name to indicate which set of climatological data was used for constructing this look-up-table.		String	18 50 2	18 50 20

Continued on Next Page...

Tag Name	Content Description	Unit	Type	Size (KVT)	Size (XML)
Spare_2			Spare	40 0 1	9 0 11
List_of_Dsds	List containing a single DSD named "Clim_DSD" for the climatology table (1 DSR only). See Table 82 for a description.			288	397
<b>Total size for KVT and XML SPH in bytes:</b>				<b>486</b>	<b>638</b>

- end of table -

### 5.3.5 DATA SET DESCRIPTORS

The Auxiliary Climatology data file contains one attached dataset, summarized by the Clim\_DSD DataSet-Descriptor of the SPH section defined in Table 81 just above.

A description of the "Data Set Descriptor Type" can be found in Table 12. The content of the Climatology dataset is described in Section 5.3.6.

### 5.3.6 Clim Data Set

The content of the Clim data set is described in Table 82. The sizes given in the tables correspond to the first example given in Section 5.3, i.e. the scenario based on GLAS data resulting in a 10.5 MB filesize. Sizes for all 3 scenarios are summarised in Table 87.

Table 82: Climatology Data Set Content Description

Tag Name	Description/Comment	Unit	Type	Size (binary)
Num_DateTime.-Ranges	Number of DateTime ranges used by this climatology (Typical values: 4 or 12)		IntAs	2
ClimDateLatLonAlt	List of Num_DateTime_Ranges structures ClimLatLonAlt containing the climatology as a function of Latitude, Longitude and Altitude (see Table 83) for a series of dates		Num.-Date-Time.-Ranges structures	11019704
<b>Total size for Climatology Data Set in bytes:</b>				<b>11019706</b>

- end of table -

Table 83: ClimLatLonAlt Data Set Content Description

Tag Name	Description/Comment	Unit	Type	Size (binary)
StartDateTime	start of timerange for which this data should be used	UTC	DateTime	12
EndDateTime	end of timerange for which this data should be used	UTC	DateTime	12
Num.Latitude.Ranges	Number of Latitude ranges used by this climatology (typical value: 18 or 90)		IntAs	2
ClimLatLonAlt	List of Num.Latitude.Ranges structures ClimLonAlt containing the climatology as a function of Longitude and Altitude (see Table 84) for the given date and latitude		Num.Lat-itude.-Ranges structures	2754900
<b>Total size for ClimLatLonAlt in bytes:</b>				<b>2754926</b>

- end of table -



Table 84: ClimLonAlt Data Set Content Description

Tag Name	Description/Comment	Unit	Type	Size (binary)
StartLatitude	start of the latitude range for which this data should be used	10-6 DegN	IntAl	4
EndLatitude	end of the latitude range for which this data should be used	10-6 DegN	IntAl	4
Num_Longitude_- Ranges	Number of Longitude ranges used by this climatology (typical value: 36 or 180)		IntAs	2
ClimLonAlt	List of Num_Longitude_Ranges structures ClimAlt containing the climatology as a function of Altitude (see Table 85) for the given Date, latitude and longitude		Num_- Longi- tude_- Ranges structures	30600
<b>Total size for ClimLonAlt in bytes:</b>				<b>30610</b>

- end of table -

Table 85: ClimAlt Data Set Content Description

Tag Name	Description/Comment	Unit	Type	Size (binary)
StartLongitude	start of the longitude range for which this data should be used	10-6 DegE	IntAl	4
EndLongitude	end of the longitude range for which this data should be used	10-6 DegE	IntAl	4
Num_Altitude_Ranges	Number of altitude ranges used by this climatology (typical values 4 or 10)		IntAs	2
ClimAlt	List of Num_Altitude_Ranges structures ClimData containing the climatology (see Table 86) for the given Date, latitude, longitude and altitude.			160
<b>Total size for ClimAlt in bytes:</b>				<b>170</b>

- end of table -

Table 86: ClimData Data Set Content Description

Tag Name	Description/Comment	Unit	Type	Size (binary)
StartAltitude	start of the altitude range for which this data should be used	m	IntAl	4
EndAltitude	stop of the altitude range for which this data should be used	m	IntAl	4
S	extinction-to-backscatter ratio	10-3 Sr	IntAl	4
S_stdev	standard deviation in the reported extinction-to-backscatter ratio	10-3 Sr	IntAl	4
<b>Total size for ClimData in bytes:</b>				<b>16</b>

- end of table -

### 5.3.7 File Size

The fixed header of the L2B Clim file is detailed in Table 8 on page 21 and the Main Product Header of the AUX\_CLM file is detailed in Table 11. The size of the Clim file varies for the 3 given examples between 0.2, 10 and 360 Mb.

Table 87: Size of Aux Clim file.

	Section	Format	Size per file example 1	Size per file example 2	Size per file example 3
<b>Header File</b>	FH	XML	699	699	699
	MPH	XML	1582	1582	1582
	SPH	XML	638	638	638
<b>Total size in bytes for HDR file</b>			<b>2919</b>	<b>2919</b>	<b>2919</b>
<b>Data Block</b>	MPH	KVT	1247	1247	1247
	SPH	KVT	486	486	486
	AuxClim ADS	Binary	11019706	381045914	192634
<b>Total size in bytes for DBL file</b>			<b>11021439</b>	<b>381047647</b>	<b>194367</b>
<b>Total size for HDR+DBL in Kb</b>			<b>10763</b>	<b>372116</b>	<b>190</b>
<b>Total size for HDR+DBL in Mb</b>			<b>10.5</b>	<b>363</b>	<b>0.2</b>

- end of table -

## 5.4 Level-2B Processing Parameters and Algorithm Settings

The Level-2B Processing Parameters file is an auxiliary input to the L2B processor. The file defines the processor settings parameters, including algorithm settings for the L2B processor. It will contain settings for all switches that control the actions performed by the processor, and the algorithm settings needed to define operation of the L2B processor.

### 5.4.1 Product Structure and Size

The Level-2B Processing Parameters file conforms to the Earth Explorer standard defined in Section 3.4, with an overall structure defined by Table 88. It is contained in one file, containing Fixed Header and Main Product Header as defined in sections 3.4.1 and 3.4.2 respectively, as well as a Specific Product Header and a single Data Set as defined in the following subsections. All headers and data sets are in XML format.

Note: a common MPH is retained for all auxiliary data files, but some parameters may in future be set to a "missing value" (GSDR RID 166).

In the tables below, all Types denoted FAoxy have been allocated 10 bytes, i.e.  $x+y=8$ .

Table 88: Structure and Size of the L2B Processing Parameters file.

Name	Description / Comment	Type	Size (XML)
Fixed_Header	The default Earth Explorer FH structure, as defined in Table 8	Structure	699
Main_Product_Header	The default Earth Explorer MPH structure, as defined in Table 11	Structure	1582
Specific_Product_Header	A specific product header, specific for this filetype, as defined in Table ....	Structure	437
Level_2B_Proc_Params	The datablock containing the actual parameter settings, as defined in Table 90.	Structure	12241
<b>Total (approximate) size for XML in bytes:</b>			<b>14959</b>

- end of table -

N.B. The MPH and SPH have no meaning for this type of auxiliary file and can be entirely removed in a future release.

### 5.4.2 File Name

The Level 2B Processing Parameters file name has the format

AE\_CCCC\_AUX\_PAR\_2B\_yyyymmddThhmmss\_yyyymmddThhmmss\_vvvv.EEF

The date/times (yyyymmddThhmmss) represent the start and stop of the validity period. This validity period will generally extend over a long period of time, each validity period representing different phases of the ADM-Aeolus mission, over which the properties of the satellite may change. The version number combined with the date makes this a unique instance of the file.

This product file has an extension .EEF to designate a single file in XML format.

### 5.4.3 File Structure

[this empty section is to be deleted]

### 5.4.4 Specific Product Header

The Specific Product Header of the AUX\_PAR\_2B XML file is defined in Table 89.

Table 89: Structure and content of the Specific Product Header of the AUX\_PAR\_2B file

Tag Name	Content Description	Unit	Type	Size (XML)
Sph.Descriptor	ASCII string describing this collection of settings		String	15 48 17
List_of_Dsds	A list of DSD's following the default Earth Explorer DSD structure, as defined in Table 12, describing the attached data set. (There is just 1 DSD in this list)		structure	0 344 0
<b>Total size for XML SPH in bytes:</b>				<b>424</b>

- end of table -

### 5.4.5 Data Set Descriptor

Only a single Data Set appears in the Aeolus Level 2B Processing Parameters data file: the Level 2B Processing Parameters GADS, as described below.

### 5.4.6 Level 2B Processing Parameters GADS

Table 90: Level 2B Processing Parameters GADS Content Description

Tag Name	Content Description	Unit	Type	Size (XML)
FH.Default.Fields	Fields responsible for populating the Fixed Header. See Table 91 for the structure definition.		Structure	0 436 0
MPH.Default.Fields	Fields responsible for populating the Main Product Header. See Table 92 for the structure definition.		structure	0 153 0
WVM.Params	Processing Parameters for the Wind Velocity Measurements. See Table 93 for the structure definition.		structure	0 5880 0
Screening.Params	Collected Screening Parameters used for testing the input files and the generated results. See Table 123 for the structure definition.		structure	0 6889 0
<b>Total size for XML L2B AuxPar GADS in bytes:</b>				<b>13358</b>

- end of table -

Table 91: FH\_Default\_Fields Content Description

Tag Name	Content Description	Unit	Type	Size (XML)
File_Description	1-line description of the file		String	0 63 0
Notes	Multi-lines free text ( <i>obsolete, no longer used in software</i> )		String	0 41 0
Mission	Aeolus		String	0 45 0
Mission_Id	AE		String	0 51 0
File_Class	1-line description of file class ( <i>obsolete, no longer used in software</i> )		String	0 51 0
File_Version	4 digits used to distinguish between versions of a file having the same validity period		IntAs	0 36 0
System	Aeolus L2BP ( <i>obsolete, no longer used in software</i> )		String	0 43 0
Creator	Aeolus L2BP ( <i>obsolete, no longer used in software</i> )		String	0 45 0
Creator_Version	Version of the tool ( <i>obsolete, no longer used in software</i> )		String	0 61 0
<b>Total size for XML L2B AuxPar FH Content in bytes:</b>				<b>436</b>

- end of table -

Table 92: MPH\_Default\_Fields Content Description

Tag Name	Content Description	Unit	Type	Size (XML)
Ref_Doc	Reference document describing the product		String	0 45 0
Software_Ver	Software version number of processing software. Format: name of processor (up to 10 char) and version number (4 char)		String	0 55 0
Proc_Center	Name of Processing Centre ( <i>obsolete, no longer used in software</i> )		String	0 53 0
<b>Total size for XML L2B AuxPar MPH Content in bytes:</b>				<b>153</b>

- end of table -

Table 93: WVM\_Params Content Description

Tag Name	Content Description	Unit	Type	Size (XML)
File_Type	File Type String		String	0 49 0
Sph_Descriptor	ASCII string describing the product		String	0 59 0
Rangebin_Mismatch_Tolerance	Tolerance beyond which Mie and Rayleigh rangebins are considered mismatched.	M	FAodoxy	0 66 0
Line_of_Sight_Wind_Flag	Flag indicating whether the horizontal or line-of-sight wind component should be reported.		Boolean	0 57 0

Continued on Next Page...

Tag Name	Content Description	Unit	Type	Size (XML)
N.Obs_Mie_Max	Maximum number of observations that may be generated for the Mie channel ( <b>obsolete, no longer used in software</b> )		IntAuc	0 35 0
N.Obs_Rayleigh_Max	Maximum number of observations that may be generated for the Rayleigh channel ( <b>obsolete, no longer used in software</b> )		IntAuc	0 45 0
BRC_Grouping_Par	Parameters controlling the possible grouping schemes applied by the L2B processing. See Table 94 for the structure definition		structure	0 790 0
Classification_Par	Parameters for the Classification algorithm. See Table 96 for the structure definition		Structure	0 632 0
Optical_Properties_Par	Parameters for the algorithms determining the optical properties of the atmosphere. See Table 100 for the structure definition.		Structure	0 410 0
Error_Quantifier_Par	Parameters for the algorithms determining the Error properties of the reported wind results. See Table 104 for structure information.		Structure	0 160 0
Common_Processing_Par	Common Processing Parameters. See Table 107, for structure information. This definition will change in line with future updates of [RD4], table 4-2.		Structure	0 978 0
Mie_Algorithm_Par	Parameters used by the Mie algorithm. See Table 111 for structure information		Structure	0 1214 0
RBC_Algorithm_Par	Parameters used by the RBC algorithm. See Table 115 for structure information		Structure	0 219 0
AMD_Matchup_Par	Parameters used by the L1B-AMD matchup algorithm. See Table 117 for structure information		Structure	0 208 0
CLM_Matchup_Par	Parameters used by the L1B-CLM matchup algorithm. See Table 119 for structure information		Structure	0 80 0
ZWC_Par	Parameters used to specify the L2B Zero-Wind Correction. See Table 121 for structure information		Structure	0 878 0
<b>Total size for XML L2B AuxPar WVM Params in bytes:</b>				<b>5880</b>

- end of table -

Table 94: Grouping parameters content description

Tag Name	Content Description	Unit	Type	Size (XML)
Grouping_Method	method to be used for composing groups of measurements, determining the maximum possible observation size after classification and accumulation. Possible methods are listed in Table 95.		Enum	0 1 0
Max_Vertical_Rangebin_Misalignment_Mie	maximum allowed vertical difference between 2 Mie rangebins with the same index. If a rangebin is found that has a larger difference a new group will be started	m	FAdoxy	0 2 0

Continued on Next Page...

Tag Name	Content Description	Unit	Type	Size (XML)
Max_Vertical_- Rangebin_- Misalignment_- Rayleigh	maximum allowed vertical difference between 2 Rayleigh rangebins with the same index. If a rangebin is found that has a larger difference a new group will be started	m	FAdoxy	0 3 0
Max_Horizontal_- Accumulation_- Length_Mie	maximum horizontal difference between first and last Mie measurement in a group. If a measurement at larger distance is found a new group will be started	km	FAdoxy	0 4 0
Max_Horizontal_- Accumulation_- Length_Rayleigh	maximum horizontal difference between first and last Rayleigh measurement in a group. If a measurement at larger distance is found a new group will be started	km	FAdoxy	0 5 0
Max_Allowed_- Gap_Between_Mie_- Measurements	maximum length of missing Mie measurements before a group definition is closed and a new group is started	km	FAdoxy	0 6 0
Max_Allowed_Gap_- Between_Rayleigh_- Measurements	maximum length of missing Rayleigh measurements before a group definition is closed and a new group is started	km	FAdoxy	0 7 0
<b>Total size for XML L2B AuxPar Grouping Params in bytes:</b>				<b>28 NOT EQUAL to expected value of 0</b>

- end of table -

Table 95: Possible Grouping methods

Name	Description
classic	a classic method that mimics the old Burst Mode way: it creates groups that always exactly match with the BRCs defined in the L1B product file.
advanced	a more advanced method that takes the thresholds defined in Table 94 above, and tries to construct groups as large as possible within the available set of measurements in a single L1B product file.
...	...

- end of table -

Table 96: Classification\_Params Content Description

Tag Name	Content Description	Unit	Type	Size (XML)
Classification_- Type_Mie	the classification type for the Mie channel. See Table 97 for valid values		Enum	0 80 0
Classification_- Type_Rayleigh	the classification type for the Rayleigh channel. See Table 97 for valid values		Enum	0 80 0
List_of_Backscatter- Ratio_Thresholds	List of BackscatterRatio_threshold structures to be used for classification of a rangebin using a threshold on the backscatter ratio. See Table 98 for structure definition (to estimate the size the list is assumed to contain 2 values).		List of structures	0 236 0

Continued on Next Page...

Tag Name	Content Description	Unit	Type	Size (XML)
List_of_Extinction_Thresholds	List of Extinction_threshold structures to be used for classification of a rangebin using a threshold on the extinction value. See Table 99 for structure definition (to estimate the size the list is assumed to contain 2 values).		List of structures	0 236 0
<b>Total size for XML L2B AuxPar Classification Params in bytes:</b>				<b>632</b>

- end of table -

Table 97: Valid values for the Classification Type fields of the L2B AuxPar Classification Params structure

Name	Description
Class_No_Clouds	Classification by assuming no clouds everywhere
Class_Copy_E2S_Input	<b>Reserved for:</b> Classification by copying the input used for the E2S (only valid for TEST product file class)
Class_Ext_Threshold	<b>Reserved for:</b> Classification by setting a threshold on the extinction
Class_Cal_Mie_Threshold	<b>Reserved for:</b> Classification by setting a threshold on the Mie backscatter value
Class_Rayleigh_Slope	<b>Reserved for:</b> Classification by setting a Threshold on the slope of the Rayleigh backscatter profile
Class_Mie_Slope	<b>Reserved for:</b> Classification by setting a Threshold on the slope of the Mie backscatter profile description
Class_Backscat_Ratio	Classification by setting a threshold on the backscatter ratio
Class_Adjacent_Mie_Backscatter	<b>Reserved for:</b> Classification by setting a Threshold on the ratio of the Mie backscatter in adjacent rangebins
Class_Adjacent_Rayleigh_Backscatter	<b>Reserved for:</b> Classification by setting a Threshold on the ratio of the Rayleigh backscatter in adjacent rangebins

- end of table -

Table 98: BackscatterRatio\_Threshold content description

Tag Name	Content Description	Unit	Type	Size (XML)
Threshold_Value	Thresholds to be used for classification of a rangebin		FAdoxy	0 66 0
Altitude	Altitude at which Threshold_Value is valid	km	FAdoxy	0 52 0
<b>Total size for XML L2B AuxPar Backscatter Threshold in bytes:</b>				<b>118</b>

- end of table -

Table 99: Extinction\_Threshold content description

Tag Name	Content Description	Unit	Type	Size (XML)
Threshold_Value	Thresholds to be used for classification of a rangebin	m-1	FAdoxy	0 66 0
Altitude	Altitude at which Threshold_Value is valid	km	FAdoxy	0 52 0

Continued on Next Page...

Tag Name	Content Description	Unit	Type	Size (XML)
<b>Total size for XML L2B AuxPar Extinction Threshold in bytes:</b>				<b>118</b>

- end of table -

Table 100: Optical\_Properties\_Params Content Description

Tag Name	Content Description	Unit	Type	Size (XML)
ScatRatio_Method	the method to be used to get the scattering ratio. See Table 101 for valid values		Enum	0 80 0
ScatRatio_Method2	A backup method to get the scattering ratio, to be used when ScatRatio_Method gives no result, i.e. returns a missing_data indicator. See Table 101 for valid values.		Enum	0 80 0
PartExt_Method	the method to be used to get the particle extinction. See Table 102 for valid values		Enum	0 80 0
MolExt_Method	the method to be used to get the molecular extinction. See Table 103 for valid values		Enum	0 80 0
Minimum_Altitude_for_Assuming_-Rho_1	Minimum Altitude at which scattering ratio (Rho) may be set to 1	km	FAdoxy	0 90 0
<b>Total size for XML L2B AuxPar Optical Properties Params in bytes:</b>				<b>410</b>

- end of table -

Table 101: Valid methods for determining backscatter ratio (Backscatter ratio method and IntAuc value for L2B PCD ADS) (compare also the values used by the L2B Measurement PCD, see table 41)

Name	Description
Scat_Ratio_from_L1B (1)	Get the backscatter ratio value from the L1B input file (available for Mie rangebins only)
Scat_Ratio_from_L1B_refined (2)	Get the refined backscatter ratio value from the L1B input file (available for Mie rangebins only)
Scat_Ratio_from_MieRayl (3)	Get the backscatter ratio value by comparing the Mie and Rayleigh useful signal
Scat_Ratio_from_RaylOnly (4)	Get the backscatter ratio value from the extinction value determined for the Rayleigh channel, by assuming a backscatter-to-extinction ratio for the particle backscatter.
Scat_Ratio_One_If_No_Mie (5)	Set the backscatter ratio value to 1.0 if no Mie information is available.
Scat_Ratio_Dont_Use (99)	don't determine the backscatter ratio (only allowed if this ratio is not used by the classification scheme, or for ScatRatio_Method2 if no backup method is needed)

- end of table -

Table 102: Valid methods for determining particle extinction

Name	Description
------	-------------

Continued on Next Page...



Name	Description
PartExt_Method_Old	Old algorithm only to be used with tests using Lite data, not to be used when processing real Aeolus data
PartExt_Method_Iterative	Iterative method described in [RD7].

- end of table -

Table 103: Valid methods for determining molecular extinction

Name	Description
MolExt_Method_Parametrised	Climatological parametrisation
MolExt_Method_Proper	Computation as a function of pressure and temperature

- end of table -

Table 104: Error\_Quantifier\_Params Content Description

Tag Name	Content Description	Unit	Type	Size (XML)
ErrorQuantMethod_-Mie	The method to be used to calculate the Error quantifier for the Mie channel. See Table 105 for valid values		Enum	0 80 0
ErrorQuantMethod_-Rayleigh	The method to be used to calculate the Error quantifier for the Rayleigh channel. See Table 106 for valid values		Enum	0 80 0
<b>Total size for XML L2B AuxPar Error Quantifier params in bytes:</b>				<b>160</b>

- end of table -

Table 105: Valid methods for determining Error Quantifier for the Mie channel

Name	Description
ErrorQuantMethod_Mie_1Bweighted	Weighted form of the L1B Mie error quantifier, see [RD7].
ErrorQuantMethod_Mie_core_sens	Derived from sensitivity analysis of the Mie core algorithm, see [RD7].

- end of table -

Table 106: Valid methods for determining Error Quantifier for the Rayleigh channel

Name	Description
ErrorQuantMethod_Ray_1Bweighted	Weighted form of the L1B Rayleigh error quantifier, see [RD7].
ErrorQuantMethod_Ray_iliad_sens	Derived from sensitivity analysis of the Rayleigh-Brillouin inversion algorithm, see [RD7].

- end of table -

Table 107: Common\_Processing\_Params Content Description

Tag Name	Content Description	Unit	Type	Size (XML)
Mie_PCD_Params	Processing parameters for Mie product confidence params SNR and backscatter-ratio. See [RD4], table 4-3, copied below as Table 108, for structure definition.		Structure	0 111 0
Mie_Core_Algorithm_Params	Processing parameters for Mie Core Algorithm. See Table 109, for structure definition. This definition will change in line with future updates of [RD4], table 4-4.		Structure	0 693 0
Corrupt_Data_Detection_Params	Parameters for corrupt data detection. See [RD3], table 8-493, copied below as Table 110, for structure definition.		Structure	0 174 0
<b>Total size for XML L2B AuxPar Common Processing Params in bytes:</b>				<b>978</b>

- end of table -

Table 108: Mie\_PCD\_Params Content Description

Tag Name	Content Description	Unit	Type	Size (XML)
Alpha_Correction	Correction factor for the calculation of the Mie SNR		FAdoxy	0 46 0
Summation_Index	Summation index for calculation of SNR and backscatter ratio		IntAul	0 36 0
<b>Total size for XML L2B AuxPar Mie PCD Params in bytes:</b>				<b>82</b>

- end of table -

Table 109: Mie\_Core\_Algorithm\_Params.Content Description

Tag Name	Content Description	Unit	Type	Size (XML)
SNR_Threshold	Threshold to switch Mie-Core processing on/off.		FAdoxy	0 40 0
Start_FWHM	Starting value for FWHM	ACCD pixel (index)	FAdoxy	0 34 0
Residual_Error_Threshold	Stop threshold for quadratic sum of differences between modelled and measured ACCD counts per pixel	A.U. (i.e. Unitless)	FAdoxy	0 62 0
Max_Iterations_Lorentz_Fit	Maximum number of iterations in Lorentz fit-loop		IntAuc	0 58 0
FWHM_Upper_Threshold	Upper threshold for FWHM of Lorentz function for quality check	ACCD pixel	FAdoxy	0 54 0
FWHM_Lower_Threshold	Lower threshold for FWHM of Lorentz function for quality check	ACCD pixel	FAdoxy	0 54 0
Peak_Height_Upper_Threshold	Relative (upper) threshold for peak height of Lorentz function	ACCD counts	FAdoxy	0 64 0
Peak_Height_Lower_Threshold	Relative (lower) threshold for peak height of Lorentz function	ACCD counts	FAdoxy	0 64 0
Peak_Location_Threshold	Peak location threshold	ACCD Pixel	FAdoxy	0 56 0

Continued on Next Page...

Tag Name	Content Description	Unit	Type	Size (XML)
Nonlinear_Optimization_Threshold	Stop threshold for Downhill Simplex algorithm merit function	A.U. (i.e. Unitless)	FAdoxy	0 74 0
Max_Iterations_-Nonlinear_Optimization	Maximum number of iterations of Downhill Simplex algorithm	A.U. (i.e. Unitless)	IntAul	0 79 0
Num_Spectral_Sub-Samples	Number of functional evaluations of Lorentz fit function for one pixel	A.U. (i.e. Unitless)	IntAul	0 54 0
<b>Total size for XML L2B AuxPar Mie Core Algo Params in bytes:</b>				<b>693</b>

- end of table -

Table 110: Corrupt\_Data\_Detection\_Params\_Content Description

Tag Name	Content Description	Unit	Type	Size (XML)
Max_Signal_Derivative	Maximum signal derivative. Maximum valid pixel intensity difference between adjacent CCD pixels.	PixelLevel	IntAus	0 52 0
Pixel_Saturation_Threshold	Pixel saturation threshold	PixelLevel	IntAus	0 62 0
<b>Total size for XML L2B AuxPar Corrupt Data Detection Params in bytes:</b>				<b>114</b>

- end of table -

Table 111: Mie\_Algorithm\_Params\_Content Description

Tag Name	Content Description	Unit	Type	Size (XML)
Copy_L1B_Mie_-Core_Algorithm_-Params	Switch to select whether L1B Mie Core Algorithm Parameters should be copied/used in the L2BP (in preference to the settings in Table 109).		Boolean	0 80 0
Mie_Height_Assignment_Method	Switch to select Mie_height assignment method. See Table 112 for valid values		Enum	0 80 0
Mie_Height_-Weight_Upper	Weight given to upper altitude of range bin (applicable when Mie_Height_Assignment_Method = use_fixed_weight).		FAdoxy	0 84 0
Skip_Mie_Non_Linearity_Correction	Switch to select whether Mie Nonlinearity Correction should be skipped in the L2BP or not		Boolean	0 55 0
Extrapolate_Mie_-Calibration_Data	Switch to select whether Mie Nonlinearity Correction (calibration data) should be extrapolated in the L2BP or not		Boolean	0 55 0
Use_Ref_Pulse_-Zero_Frequency	Switch to select whether (Mie) Reference Pulse Zero Frequency should be used in the L2BP or not		Boolean	0 55 0
Use_Meas_Zero_Frequency	Switch to select whether (Mie) Measurement Channel Zero Frequency should be used in the L2BP or not		Boolean	0 55 0
Offset_Subtraction_-Col20_Weight	Weight given to ACCD column 20 in (Mie) offset subtraction		FAdoxy	0 84 0

Continued on Next Page...

Tag Name	Content Description	Unit	Type	Size (XML)
List_of_SNR_Thresholds	List of SNR_threshold structures to be used for quality control of L2B Mie hlos retrievals. See Table 113 for structure definition. (3 altitude layers with different thresholds are assumed for the size calculation)		List of structures	0 666 0
<b>Total size for XML L2B AuxPar Mie Algo Params in bytes:</b>				<b>1214</b>

- end of table -

Table 112: Valid methods for Mie height assignment

Name	Description
use_fixed_weight	Use fixed weights for upper and lower altitudes of range bin.
...	...

- end of table -

Table 113: SNR\_Threshold content description

Tag Name	Content Description	Unit	Type	Size (XML)
Threshold_Value	Threshold to be used for quality control of L2B Mie hlos retrievals		FAdoxy	0 66 0
Altitude_Low	Lowest altitude at which Threshold_Value is valid	km	FAdoxy	0 52 0
Altitude_High	Highest altitude at which Threshold_Value is valid	km	FAdoxy	0 52 0
Altitude_Reference	Description of reference level for altitude. See Table 114 for valid values		String	0 52 0
<b>Total size for XML L2B AuxPar SNR Thresholds in bytes:</b>				<b>222</b>

- end of table -

Table 114: Valid methods for Altitude\_Reference

Name	Description
DEM	SNR_Threshold altitudes are referenced to the DEM
geoid	SNR_Threshold altitudes are referenced to the geoid

- end of table -

Table 115: RBC\_Algorithm\_Params Content Description

Tag Name	Content Description	Unit	Type	Size (XML)
Rayleigh_Height_Assignment_Method	Switch to select Rayleigh_height assignment method. See Table 116 for valid values		Enum	0 80 0
Rayleigh_Height_Weight_Upper	Weight given to upper altitude of range bin (applicable when Rayleigh_Height_Assignment_Method = use_fixed_weight)		FAdoxy	0 84 0

Continued on Next Page...

Tag Name	Content Description	Unit	Type	Size (XML)
Do_Mie_Decontamination	Switch to select whether Mie_Decontamination should be done in the L2BP or not (i.e. if it is not already done in the L1BP) (JK: is this still relevant?)		Boolean	0 55 0
<b>Total size for XML L2B AuxPar RBC Algo Params in bytes:</b>				<b>219</b>

- end of table -

Table 116: Valid methods for Rayleigh height assignment

Name	Description
use_fixed_weight	Use fixed weights for upper and lower altitudes of range bin.
Calculate_from_pressure_and_temperature	Calculate from pressure and temperature

- end of table -

Table 117: AMD\_Matchup\_Params Content Description

Tag Name	Content Description	Unit	Type	Size (XML)
Matchup_Method	Matchup method to be used for L1B-AMD matchup. See Table 118 for a list of valid values.		Enum	0 80 0
Max_Allowed_Time_Diff	Maximum allowed time difference in seconds between L1B BRC and AMD DSR	s	IntAul	0 64 0
Max_Allowed_Distance	Maximum allowed distance in kilometers between L1B BRC and AMD DSR	km	IntAul	0 64 0
<b>Total size for XML L2B AuxPar AMD Matchup params in bytes:</b>				<b>208</b>

- end of table -

Table 118: Valid values for AMD\_Matchup\_Params parameter Matchup\_Method

Name	Description
Dummy	One-for-one between L1B BRC and AMD DSR
Nearest_Neighbour	Nearest-neighbour in space and time
...	...

- end of table -

Table 119: CLM\_Matchup\_Params Content Description

Tag Name	Content Description	Unit	Type	Size (XML)
Matchup_Method	Matchup method to be used for L1B-CLM matchup. See Table 120 for a list of valid values.		Enum	0 80 0
<b>Total size for XML L2B AuxPar CLM Matchup Params in bytes:</b>				<b>80</b>

- end of table -

Table 120: Valid values for CLM\_Matchup\_Params parameter Matchup\_Method

Name	Description
Dummy	Always use the first available profile
Nearest_Neighbour	Nearest-neighbour in space and time
...	...

- end of table -

Table 121: ZWC\_Params Content Description

Tag Name	Content Description	Unit	Type	Size (XML)
ZWC_Scheme_Mie	Zero-Wind Correction scheme to be used for L2B Mie processing. See Table 122 for a list of valid values.		Enum	0 80 0
ZWC_Scheme_-Rayleigh	Zero-Wind Correction scheme to be used for L2B Rayleigh processing. See Table 122 for a list of valid values.		Enum	0 80 0
Mie_Ground_Correction_Weighting	Mie ground correction weighting factor	Scalar (no unit)	FAdoxy	0 90 0
Mie_HBE_Ground_Correction_Weighting	Mie HBE ground correction weighting factor	Scalar (no unit)	FAdoxy	0 98 0
Rayleigh_Ground_Correction_Weighting	Rayleigh ground correction weighting factor	Scalar (no unit)	FAdoxy	0 100 0
Rayleigh_HBE_Ground_Correction_Weighting	Rayleigh HBE ground correction weighting factor	Scalar (no unit)	FAdoxy	0 108 0
Mie_Rayleigh_Ground_Correction_Weighting	Mie-Rayleigh ground correction weighting factor	Scalar (no unit)	FAdoxy	0 108 0
Mie_Rayleigh_HBE_Ground_Correction_Weighting	Mie-Rayleigh HBE ground correction weighting factor	Scalar (no unit)	FAdoxy	0 112 0
Mie_Rayleigh_Ground_Correction_Offset	Mie-Rayleigh ground correction weighting factor	m/s	FAdoxy	0 102 0
<b>Total size for XML L2B AuxPar ZWC Params in bytes:</b>				<b>878</b>

- end of table -

Table 122: Valid values for ZWC\_Params parameters ZWC\_Scheme\_Mie and ZWC\_Scheme\_Rayleigh

Name	Description
ZWC_Scheme_use_total_L1B_corr	Use total L1B correction from the L1B GWD ADS
ZWC_Scheme_copy_L1B_settings	Re-compute using L1B settings (not recommended)
ZWC_Scheme_use_L2B_settings	Re-compute using L2B settings from AUX_PAR_2B ZWC_Params for the factors to weight the L1B GWD ADS ground correction velocities

- end of table -

Table 123: Screening\_Params Content Description

Tag Name	Content Description	Unit	Type	Size (XML)
L1B_Screening_Params	Parameters used for screening the L1B input file. See Table 124 for the structure definition.		Structure	0 6721 0
L2B_AMD_Screening_Params	Parameters used for screening the L2B-AMD input file. See Table 133 for the structure definition.		Structure	0 168 0
<b>Total size for XML L2B AuxPar Screening Params in bytes:</b>				<b>6889</b>

- end of table -

Table 124: L1B\_Screening\_Params Content Description

Tag Name	Content Description	Unit	Type	Size (XML)
L1B_Geolocation_Screening_Params	Parameters used for screening the L1B geolocations from the L1B input file. See Table 125 for the structure definition.		Structure	0 800 0
L1B_Obs_Screening_Params	Parameters used for screening the L1B observations from the L1B input file. See Table 126 for the structure definition.		Structure	0 1733 0
L1B_Mie_Meas_Screening_Params	Parameters used for screening the L1B Mie Measurements from the L1B input file. See Table 127 for the structure definition.		Structure	0 1627 0
L1B_Rayleigh_Meas_Screening_Params	Parameters used for screening the L1B Rayleigh Measurements from the L1B input file. See Table 128 for the structure definition.		Structure	0 1361 0
L1B_Cal_Char_Data_Screening_Params	Parameters used for screening the L1B Calibration and Characterization Data from the L1B input file. See Table 129 for the structure definition.		Structure	0 900 0
L1B_GWD_ADS_Screening_Params	Parameters used for screening the L1B GWD_ADS dataset from the L1B input file. See Table 132 for the structure definition.		Structure	0 300 0
<b>Total size for XML L2B AuxPar L1B Screening Params in bytes:</b>				<b>6721</b>

- end of table -

Table 125: L1B\_Geolocation\_Screening\_Params Content Description

Tag Name	Content Description	Unit	Type	Size (XML)
Latitude_min	Minimum latitude allowed in L1B Geolocation Data	degrees	FAdoxy	0 50 0
Latitude_max	Maximum latitude allowed in L1B Geolocation Data	degrees	FAdoxy	0 50 0
Longitude_min	Minimum longitude allowed in L1B Geolocation Data	degrees	FAdoxy	0 50 0
Longitude_max	Maximum longitude allowed in L1B Geolocation Data	degrees	FAdoxy	0 50 0
Altitude_min	Minimum altitude allowed in L1B Geolocation Data	km	FAdoxy	0 50 0

Continued on Next Page...

Tag Name	Content Description	Unit	Type	Size (XML)
Altitude_max	Maximum altitude allowed in L1B Geolocation Data	km	FAdoxy	0 50 0
Altitude_DEM_min	Minimum DEM altitude allowed in L1B Geolocation Data	km	FAdoxy	0 50 0
Altitude_DEM_max	Maximum DEM altitude allowed in L1B Geolocation Data	km	FAdoxy	0 50 0
Geoid_Separation_min	Minimum geoid separation allowed in L1B Geolocation Data	km	FAdoxy	0 50 0
Geoid_Separation_max	Maximum geoid separation allowed in L1B Geolocation Data	km	FAdoxy	0 50 0
Topocentric_Elevation_min	Minimum topocentric elevation allowed in L1B Geolocation Data	degrees	FAdoxy	0 50 0
Topocentric_Elevation_max	Maximum topocentric elevation allowed in L1B Geolocation Data	degrees	FAdoxy	0 50 0
Topocentric_Azimuth_min	Minimum topocentric azimuth allowed in L1B Geolocation Data	degrees	FAdoxy	0 50 0
Topocentric_Azimuth_max	Maximum topocentric azimuth allowed in L1B Geolocation Data	degrees	FAdoxy	0 50 0
AOCS_LOS_Velocity_min	Minimum AOCS LOS Velocity allowed in L1B Geolocation Data	m/s	FAdoxy	0 50 0
AOCS_LOS_Velocity_max	Maximum AOCS LOS Velocity allowed in L1B Geolocation Data	m/s	FAdoxy	0 50 0
<b>Total size for XML L2B AuxPar L1B Geoloc Screening params in bytes:</b>				<b>800</b>

- end of table -

Table 126: L1B\_Obs\_Screening\_Params Content Description

Tag Name	Content Description	Unit	Type	Size (XML)
L1B_Laser_Freq_Unlocked_Threshold	Threshold on the value of nmeas with laser_freq_unlocked (see element 10 in table 17 of section 5.3 of [RD1])		IntAl	0 83 0
L1B_Ref_Pulses_Unlocked_Threshold	Threshold on the value of nrefpulses with laser_freq_unlocked (see element 11 in table 17 of section 5.3 of [RD1])		IntAl	0 83 0
L1B_Laser_Freq_Offset_Threshold	Threshold on the value of average laser freq. offset (see element 12 in table 17 of section 5.3 of [RD1])	GHz	FAdoxy	0 84 0
L1B_Laser_UV_Energy_Threshold	Threshold on the value of average laser UV energy (see element 13 in table 17 of section 5.3 of [RD1])	mJ	FAdoxy	0 74 0
L1B_Laser_Freq_Offs_Stdev_Threshold	Threshold on the value of Standard deviation for laser frequency offset (see element 14 in table 17 of section 5.3 of [RD1])	GHz	FAdoxy	0 92 0
L1B_Laser_UV_Energy_Stdev_Threshold	Threshold on the value of Standard deviation for laser pulse UV energy (see element 15 in table 17 of section 5.3 of [RD1])	mJ	FAdoxy	0 86 0
L1B_Mie_Mean_Emit_Freq_Min	Minimum allowed value for Mie mean emitted frequency (see element 16 in table 17 of section 5.3 of [RD1])	GHz	FAdoxy	0 64 0
L1B_Mie_Mean_Emit_Freq_Max	Maximum allowed value for Mie mean emitted frequency (see element 16 in table 17 of section 5.3 of [RD1])	GHz	FAdoxy	0 74 0

Continued on Next Page...



Tag Name	Content Description	Unit	Type	Size (XML)
L1B_Mie_Emit_- Freq_Stdev_Thresh- old	Threshold on the value of Mie emitted frequency standard deviation (see element 17 in table 17 of section 5.3 of [RD1])	GHz	FAdoxy	0 88 0
L1B_Rayleigh_- Mean_Emit_Freq_- Min	Minimum allowed value for Rayleigh mean emitted frequency (see element 18 in table 17 of section 5.3 of [RD1])	GHz	FAdoxy	0 84 0
L1B_Rayleigh_- Mean_Emit_Freq_- Max	Maximum allowed value for Rayleigh mean emitted frequency (see element 18 in table 17 of section 5.3 of [RD1])	GHz	FAdoxy	0 84 0
L1B_Rayleigh_- Emit_Freq_Stdev_- Threshold	Threshold on the value of Rayleigh emitted frequency standard deviation (see element 19 in table 17 of section 5.3 of [RD1])	GHz	FAdoxy	0 98 0
L1B_Sat_Not_on_- Target_Threshold	Threshold on the value of nmeas with sat_not_on_target (see element 20 in table 17 of section 5.3 of [RD1])		IntAl	0 79 0
L1B_Mie_Corrupt_- Threshold	Threshold on the value of nmeas with corrupt Mie meas. (see element 30 in table 17 of section 5.3 of [RD1])		IntAl	0 67 0
L1B_Rayleigh_Corrupt_- Threshold	Threshold on the value of nmeas with corrupt Rayleigh meas. (see element 31 in table 17 of section 5.3 of [RD1])		IntAl	0 77 0
L1B_Mie_Ref_- Pulses_Corrupt_- Threshold	Threshold on the value of nmeas with corrupt Mie ref. Pulses (see element 32 in table 17 of section 5.3 of [RD1])		IntAl	0 89 0
L1B_Rayl_Ref_- Pulses_Corrupt_- Threshold	Threshold on the value of nmeas with corrupt Rayleigh ref. Pulses (see element 33 in table 17 of section 5.3 of [RD1])		IntAl	0 91 0
L1B_Mie_Invalid_- Meas_Threshold	Threshold on the value of num_of_mie_invalid_measurements (see element 40 in table 17 of section 5.3 of [RD1])		IntAl	0 77 0
L1B_Mie_Invalid_- Ref_Pulses_Thresh- old	Threshold on the value of num_of_mie_invalid_reference_pulse (see element 41 in table 17 of section 5.3 of [RD1])		IntAl	0 89 0
L1B_Rayl_Invalid_- Meas_Threshold	Threshold on the value of num_of_rayleigh_invalid_measurements (see element 42 in table 17 of section 5.3 of [RD1])		IntAl	0 79 0
L1B_Rayl_Invalid_- Ref_Pulses_Thresh- old	Threshold on the value of num_of_rayleigh_invalid_reference_pulse (see element 43 in table 17 of section 5.3 of [RD1])		IntAl	0 91 0
<b>Total size for XML L2B AuxPar L1B Obs Screening Params in bytes:</b>				<b>1733</b>

- end of table -

Table 127: L1B\_Mie\_Meas\_Screening\_Params Content Description

Tag Name	Content Description	Unit	Type	Size (XML)
L1B_Mie_Meas_In- valid_Ref_Pulses_- Threshold	Threshold on the value of num_of_mie_invalid_reference_pulses (see element 1 in table 19 of section 5.3 of [RD1])		IntAl	0 99 0
L1B_Avg_Laser_- Freq_Offset_Min	Minimum allowed value for Avg_Laser_Frequency_Offset (see element 2 in table 19 of section 5.3 of [RD1])	GHz	FAdoxy	0 80 0

Continued on Next Page...

Tag Name	Content Description	Unit	Type	Size (XML)
L1B_Avg_Laser_- Freq_Offset_Max	Maximum allowed value for Avg_Laser_- Frequency_Offset (see element 2 in table 19 of section 5.3 of [RD1])	GHz	FAdoxy	0 80 0
L1B_Avg_UV_En- ergy_Min	Minimum allowed value for Avg_UV_En- ergy (see element 3 in table 19 of section 5.3 of [RD1])	mJ	FAdoxy	0 58 0
L1B_Avg_UV_En- ergy_Max	Maximum allowed value for Avg_UV_En- ergy (see element 3 in table 19 of section 5.3 of [RD1])	mJ	FAdoxy	0 58 0
L1B_Laser_Freq_Of- set_Stdev_Threshold	Threshold on the value for Laser_Fre- quency_Offset_Std_Dev (see element 4 in table 19 of section 5.3 of [RD1])	GHz	FAdoxy	0 96 0
L1B_UV_Energy_- Stddev_Threshold	Threshold on the value for UV_Energy_- Std_Dev (see element 5 in table 19 of sec- tion 5.3 of [RD1])	mJ	FAdoxy	0 78 0
L1B_Vel_of_Att_Un- certainty_Error_Min	Minimum allowed value for Velocity_of_At- titude_Uncertainty_Error (see element 6 in table 19 of section 5.3 of [RD1])	m/s	FAdoxy	0 88 0
L1B_Vel_of_Att_Un- certainty_Error_Max	Maximum allowed value for Velocity_of_- Attitude_Uncertainty_Error (see element 6 in table 19 of section 5.3 of [RD1])	m/s	FAdoxy	0 88 0
L1B_Mie_Mean_- Emitted_Freq_Min	Minimum allowed value for Mie_Mean_- Emitted_Frequency (see element 7 in table 19 of section 5.3 of [RD1])	GHz	FAdoxy	0 80 0
L1B_Mie_Mean_- Emitted_Freq_Max	Maximum allowed value for Mie_Mean_- Emitted_Frequency (see element 7 in table 19 of section 5.3 of [RD1])	GHz	FAdoxy	0 80 0
L1B_Mie_Emitted_- Freq_Stddev_Thresh- old	Threshold on the value of Mie_Emitted_- Frequency_Std_Dev (see element 8 in table 19 of section 5.3 of [RD1])	GHz	FAdoxy	0 94 0
L1B_Meas_Ref- erence_Pulse_- FWHM_Min	Minimum allowed value for L1B PCD measurement-level parameter Reference_- Pulse_FWHM	PixelIndex	FAdoxy	0 92 0
L1B_Meas_Ref- erence_Pulse_- FWHM_Max	Maximum allowed value for L1B PCD measurement-level parameter Reference_- Pulse_FWHM	PixelIndex	FAdoxy	0 92 0
L1B_Scattering_Ra- tio_Min	Minimum allowed value for Scattering_Ra- tio_Mie (see element 2 in table 21 of section 5.3 of [RD1])		FAdoxy	0 64 0
L1B_Scattering_Ra- tio_Max	Maximum allowed value for Scattering_Ra- tio_Mie (see element 2 in table 21 of section 5.3 of [RD1])		FAdoxy	0 64 0
L1B_Mie_SNR_- Threshold	Threshold on the value of Mie.Signal.to_- Noise_Ratio (see element 3 in table 21 of section 5.3 of [RD1])	unitless	FAdoxy	0 58 0
Mie_Ground_Bin_- Thickness_Thresh- old	Threshold on the part of the ground bin that is above the surface according to the DEM.	m	FAdoxy	0 80 0
Max_Signal_Deriva- tive	Threshold on the Mie spectrum to be able to detect corrupt channels	PixelLevel	IntAs	0 54 0
Pixel_Saturation_- Threshold	Threshold on the Mie spectral channels to be able to detect saturated channels	PixelLevel	IntAs	0 64 0

Continued on Next Page...

Tag Name	Content Description	Unit	Type	Size (XML)
Ignore_Mie_Meas_Invalid_Switch	Switch to select whether the L1B flag indicating an Invalid Mie Measurement should be ignored in the L2BP or not		Boolean	0 80 0
<b>Total size for XML L2B AuxPar L1B Mie Measurements Screening Params in bytes:</b>				<b>1627</b>

- end of table -

Table 128: L1B\_Rayleigh\_Meas\_Screening\_Params Content Description

Tag Name	Content Description	Unit	Type	Size (XML)
L1B_Rayleigh_Meas_Invalid_Ref_Pulses_Threshold	Threshold on the value of num_of_Rayleigh_invalid_reference_pulses (see element 1 in table 23 of section 5.3 of [RD1])		IntAI	0 109 0
L1B_Avg_Laser_Freq_Offset_Min	Minimum allowed value for Avg_Laser_Frequency_Offset (see element 2 in table 23 of section 5.3 of [RD1])	GHz	FAdoxy	0 80 0
L1B_Avg_Laser_Freq_Offset_Max	Maximum allowed value for Avg_Laser_Frequency_Offset (see element 2 in table 23 of section 5.3 of [RD1])	GHz	FAdoxy	0 80 0
L1B_Avg_UV_Energy_Min	Minimum allowed value for Avg_UV_Energy (see element 3 in table 23 of section 5.3 of [RD1])	mJ	FAdoxy	0 58 0
L1B_Avg_UV_Energy_Max	Maximum allowed value for Avg_UV_Energy (see element 3 in table 23 of section 5.3 of [RD1])	mJ	FAdoxy	0 58 0
L1B_Laser_Freq_Offset_Stdev_Threshold	Threshold on the value of Laser_Frequency_Offset_Std_Dev (see element 4 in table 23 of section 5.3 of [RD1])	GHz	FAdoxy	0 96 0
L1B_UV_Energy_Stdev_Threshold	Threshold on the value of UV_Energy_Std_Dev (see element 5 in table 23 of section 5.3 of [RD1])	mJ	FAdoxy	0 74 0
L1B_Vel_of_Att_Uncertainty_Error_Min	Minimum allowed value for Velocity_of_Attitude_Uncertainty_Error (see element 6 in table 23 of section 5.3 of [RD1])	m/s	FAdoxy	0 88 0
L1B_Vel_of_Att_Uncertainty_Error_Max	Maximum allowed value for Velocity_of_Attitude_Uncertainty_Error (see element 6 in table 23 of section 5.3 of [RD1])	m/s	FAdoxy	0 88 0
L1B_Rayleigh_Mean_Emitted_Freq_Min	Minimum allowed value for Rayleigh_Mean_Emitted_Frequency (see element 7 in table 23 of section 5.3 of [RD1])	GHz	FAdoxy	0 90 0
L1B_Rayleigh_Mean_Emitted_Freq_Max	Maximum allowed value for Rayleigh_Mean_Emitted_Frequency (see element 7 in table 23 of section 5.3 of [RD1])	GHz	FAdoxy	0 90 0
L1B_Rayleigh_Emitted_Freq_Stdev_Threshold	Threshold on the value of Rayleigh_Emitted_Frequency_Std_Dev (see element 8 in table 23 of section 5.3 of [RD1])	GHz	FAdoxy	0 104 0
L1B_Rayleigh_SNR_Min	Minimum allowed value for Rayleigh_Signal_to_Noise_Ratio_Channel_A and Rayleigh_Signal_to_Noise_Ratio_Channel_B (see elements 2 and 3 in table 25 of section 5.3 of [RD1])	unitless	FAdoxy	0 56 0

Continued on Next Page...

Tag Name	Content Description	Unit	Type	Size (XML)
L1B_Rayleigh_-SNR_Max	Maximum allowed value for Rayleigh-Signal_to_Noise_Ratio_Channel_A and Rayleigh.Signal_to_Noise_Ratio_Channel_B (see elements 2 and 3 in table 25 of section 5.3 of [RD1])	unitless	FAdoxy	0 56 0
Rayleigh_Ground_-Bin_Thickness_-Threshold	Threshold on the part of the ground bin that is above the surface according to the DEM.	m	FAdoxy	0 90 0
Pixel_Saturation_-Threshold	Threshold on the Rayleigh channels to be able to detect saturated signals	PixelLevel	IntAs	0 64 0
Ignore_Rayleigh_-Meas_Invalid_Switch	Switch to select whether the L1B flag indicating an Invalid Rayleigh Measurement should be ignored in the L2BP or not		Boolean	0 80 0
<b>Total size for XML L2B AuxPar L1B Rayleigh Meas. Screening Params in bytes:</b>				<b>1361</b>

- end of table -

Table 129: L1B\_Cal\_Char\_Data\_Screening\_Params Content Description

Tag Name	Content Description	Unit	Type	Size (XML)
L1B_Sat_Char_-Data_Screening_-Params	Parameters used for screening the L1B satellite characterization data. See Table 130 for the structure definition.		Structure	0 100 0
L1B_Mie_Resp_-Calib_Data_Screening_Params	Parameters used for screening the L1B Mie response calibration data. See Table 131 for the structure definition.		Structure	0 800 0
<b>Total size for XML L2B AuxPar L1B Cal Char Data Screening Params in bytes:</b>				<b>900</b>

- end of table -

Table 130: L1B\_Sat\_Char\_Data\_Screening\_Params Content Description

Tag Name	Content Description	Unit	Type	Size (XML)
Tripod_Obscur_-Corr_min	Minimum tripod obscuration correction allowed in L1B products	Unitless	Int	0 50 0
Tripod_Obscur_-Corr_max	Maximum tripod obscuration correction allowed in L1B products	Unitless	Int	0 50 0
<b>Total size for XML L2B AuxPar L1B Sat Char Data Screening Params in bytes:</b>				<b>100</b>

- end of table -

Table 131: L1B\_Mie\_Resp\_Calib\_Data\_Screening\_Params Content Description

Tag Name	Content Description	Unit	Type	Size (XML)
Meas_Resp_min	Minimum Mie measurement channel response allowed in L1B products	PixelIndex	FAdoxy	0 50 0
Meas_Resp_max	Maximum Mie measurement channel response allowed in L1B products	PixelIndex	FAdoxy	0 50 0

Continued on Next Page...

Tag Name	Content Description	Unit	Type	Size (XML)
Meas_Err_Resp_min	Minimum Mie measurement channel response error (nonlinearity correction) allowed in L1B products	PixelIndex	FAdoxy	0 50 0
Meas_Err_Resp_max	Maximum Mie measurement channel response error (nonlinearity correction) allowed in L1B products	PixelIndex	FAdoxy	0 50 0
Ref_Pulse_Resp_min	Minimum Mie internal reference pulse channel response allowed in L1B products	PixelIndex	FAdoxy	0 50 0
Ref_Pulse_Resp_max	Maximum Mie internal reference pulse channel response allowed in L1B products	PixelIndex	FAdoxy	0 50 0
Ref_Pulse_Err_Resp_min	Minimum Mie internal reference pulse channel response error (nonlinearity correction) allowed in L1B products	PixelIndex	FAdoxy	0 50 0
Ref_Pulse_Err_Resp_max	Maximum Mie internal reference pulse channel response error (nonlinearity correction) allowed in L1B products	PixelIndex	FAdoxy	0 50 0
Ref_Pulse_Zero_Frequency_min	Minimum Mie internal reference pulse channel zero frequency allowed in L1B products	PixelIndex	FAdoxy	0 50 0
Ref_Pulse_Zero_Frequency_max	Maximum Mie internal reference pulse channel zero frequency allowed in L1B products	PixelIndex	FAdoxy	0 50 0
Ref_Pulse_Mean_Sensitivity_min	Minimum Mie internal reference pulse channel mean sensitivity allowed in L1B products	Pixel-Index/ GHz	FAdoxy	0 50 0
Ref_Pulse_Mean_Sensitivity_max	Maximum Mie internal reference pulse channel mean sensitivity allowed in L1B products	Pixel-Index/ GHZ	FAdoxy	0 50 0
Meas_Zero_Frequency_min	Minimum Mie measurement channel zero frequency allowed in L1B products	PixelIndex	FAdoxy	0 50 0
Meas_Zero_Frequency_max	Maximum Mie measurement channel zero frequency allowed in L1B products	PixelIndex	FAdoxy	0 50 0
Meas_Mean_Sensitivity_min	Minimum Mie measurement channel mean sensitivity allowed in L1B products	Pixel-Index/ GHz	FAdoxy	0 50 0
Meas_Mean_Sensitivity_max	Maximum Mie measurement channel mean sensitivity allowed in L1B products	Pixel-Index/ GHz	FAdoxy	0 50 0
<b>Total size for XML L2B AuxPar L1B Mie Resp. Calib. Data Scr. Params in bytes:</b>				<b>800</b>

- end of table -

Table 132: L1B.GWD.ADS.Screening.Params Content Description

Tag Name	Content Description	Unit	Type	Size (XML)
Zero_Wind_Corr_min	Minimum zero-wind correction allowed in L1B products	m/s	FAdoxy	0 50 0
Zero_Wind_Corr_max	Maximum zero-wind correction allowed in L1B products	m/s	FAdoxy	0 50 0
Zero_Wind_Corr_Weight_Factor_min	Minimum zero-wind correction weighting factor allowed in L1B products	unitless	FAdoxy	0 50 0

Continued on Next Page...

Tag Name	Content Description	Unit	Type	Size (XML)
Zero_Wind_Corr_Weight_Factor_max	Maximum zero-wind correction weighting factor allowed in L1B products	unitless	FAdoxy	0 50 0
Mie_Rayl_Correction_Offset_min	Minimum Mie-Rayleigh correction offset allowed in L1B products	m/s	FAdoxy	0 50 0
Mie_Rayl_Correction_Offset_max	Maximum Mie-wRayleigh correction offset allowed in L1B products	m/s	FAdoxy	0 50 0
<b>Total size for XML L2B AuxPar L1B GWD ADS Screening Params in bytes:</b>				<b>300</b>

- end of table -

Table 133: L2B\_AMD\_Screening\_Params Content Description

Tag Name	Content Description	Unit	Type	Size (XML)
L2B_AMD_p_min	Minimum pressure allowed in a pressure profile (when a tested profile is outside this range the L2B_AMD_Screening_QC field in table 30 of section 5.3 of [RD1] is set to L2B_AMD_Unlikely_Profile)	Pa	FAdoxy	0 42 0
L2B_AMD_p_max	Maximum pressure allowed in a pressure profile (when a tested profile is outside this range the L2B_AMD_Screening_QC field in table 30 of section 5.3 of [RD1] is set to L2B_AMD_Unlikely_Profile)	Pa	FAdoxy	0 42 0
L2B_AMD_T_min	Minimum temperature allowed in a temperature profile (when a tested profile is outside this range the L2B_AMD_Screening_QC field in table 30 of section 5.3 of [RD1] is set to L2B_AMD_Unlikely_Profile)	K	FAdoxy	0 42 0
L2B_AMD_T_max	Maximum temperature allowed in a temperature profile (when a tested profile is outside this range the L2B_AMD_Screening_QC field in table 30 of section 5.3 of [RD1] is set to L2B_AMD_Unlikely_Profile)	K	FAdoxy	0 42 0
<b>Total size for XML L2B AuxPar L2B AMD Screening Params in bytes:</b>				<b>168</b>

- end of table -

## 5.5 Files supplied to the L2-PF and National Weather Services

The need for predicted orbit files (MPL\_ORBPRES) at the L2-PF (i.e. ECMWF) has been discussed in Section 1.3. L1B template files with predicted orbit locations would be an alternative. The L2-PF and National Weather Services need to receive Rayleigh-Brillouin Correction data (AUX\_RBC\_L2) as often as it is generated, ideally every time an Instrument Spectral Registration is performed. The working assumption is that L1B data (ALD\_U\_N\_1B) transmitted to the L2-PF and National Weather Services will be in TGZ format (XML HDR plus DBL converted to BUFR) - see Section 1.3.

## 5.6 Level-2C Processing Parameters and Algorithm Settings

The Level-2C Processing Parameters file is notionally an auxiliary input to the L2C processor. The file defines the processor settings parameters, including algorithm settings for the L2C processor. It will contain settings for all switches that control the actions performed by the processor, and the algorithm settings needed to define operation of the L2C processor. In practice, Level-2C Processing Parameters are defined by the operational data assimilation system at ECMWF. The file will be produced by ECMWF to record the settings used for assimilation of L1B/L2B Aeolus data within the ECMWF assimilation system. The evolution of ECMWF processing of Aeolus data can be tracked by examining copies of Level-2C Processing

Parameters files stored in the Aeolus Ground Segment (e.g. the LTA).

### 5.6.1 Product Structure and Size

The Level-2C Processing Parameters file conforms to the Earth Explorer standard defined in Section 3.4, with an overall structure defined by Table 134. It is contained in one product file, containing Fixed Header and Main Product Header as defined in sections 3.4.1 and 3.4.2 respectively, as well as a Specific Product Header and a single Data Set as defined in the following subsections. All headers and data sets are in XML format.

Note: a common MPH is retained for all auxiliary data files, but some parameters may in future be set to a "missing value" (GSDR RID 166).

In the tables below, all Types denoted FAodoxy have been allocated 10 bytes, i.e.  $x+y=8$ .

Table 134: Structure and Size of the L2B Processing Parameters file.

Name	Description / Comment	Type	Size (XML)
Fixed_Header	The default Earth Explorer FH structure, as defined in Table 8	Structure	699
Main_Product_Header	The default Earth Explorer MPH structure, as defined in Table 11	Structure	1582
Specific_Product_Header	A specific product header, specific for this filetype, as defined in Table ...	Structure	924
Level_2C_Proc_Params	The datablock containing the actual parameter settings, as defined in Table ...	Structure	15828
Total (approximate) size for XML in bytes:			<b>19034</b>

- end of table -

N.B. The MPH and SPH have no meaning for this type of auxiliary file and can be entirely removed in a future release.

### 5.6.2 File Name

The Level 2C Processing Parameters file name has the format

AE\_CCCC\_AUX\_PAR\_2C\_yyyymmddThhmmss\_yyyymmddThhmmss.vvvv.EEF

The date/times (yyymmddThhmmss) represent the start and stop of the validity period. This validity period will generally extend over a long period of time, each validity period representing different phases of the ADM-Aeolus mission, over which the properties of the satellite may change. The version number combined with the date makes this a unique instance of the file.

This product file has an extension .EEF to designate a single file in XML format.

### 5.6.3 File Structure

[this empty section is to be deleted]

### 5.6.4 Specific Product Header

The Specific Product Header of the AUX\_PAR\_2C XML file is defined in Table 135.

Table 135: Structure and content of the Specific Product Header of the AUX\_PAR\_2C file

Tag Name	Content Description	Unit	Type	Size (XML)
Sph_Descriptor	ASCII string describing this collection of settings		String	15 48 17
Spare				0 500 0
List_of_Dsds	A list of DSD's following the default Earth Explorer DSD structure, as defined in Table 12, describing the attached data set. (There is just 1 DSD in this list)		structure	0 344 0
<b>Total size for XML SPH in bytes:</b>				<b>924</b>

- end of table -

### 5.6.5 Data Set Descriptor

Only a single Data Set appears in the Aeolus Level 2C Processing Parameters data file: the Level 2C Processing Parameters GADS, as described below.

### 5.6.6 Level 2C Processing Parameters GADS

Table 136: Level 2C Processing Parameters GADS Content Description

Tag Name	Content Description	Unit	Type	Size (XML)
L2C_FH_Default_Fields	Fields responsible for populating the Fixed Header. See Table 91 on page 76 for the structure definition.		Structure	0 436 0
L2C_MPH_Default_Fields	Fields responsible for populating the Main Product Header. See Table 92 for the structure definition.		structure	0 153 0
L2C_Assim_Params	Processing Parameters for the assimilation of L2B data. See Table 137 for the structure definition.		structure	0 5742 0
Screening_Params	Collected Screening Parameters used for testing the input files and the generated results. See Table 138 for the structure definition.		structure	0 9497 0
<b>Total size for XML L2B AuxPar GADS in bytes:</b>				<b>15828</b>

- end of table -

Table 137: L2C\_Assim\_Params Content Description

Tag Name	Content Description	Unit	Type	Size (XML)
File_Type	File Type String		String	0 49 0
Sph_Descriptor	ASCII string describing the product		String	0 59 0
Spare or whitespace				0 5634 0
<b>Total size for XML L2C AuxPar L2C Assim. Params in bytes:</b>				<b>5742</b>

- end of table -



Table 138: L2C\_Screening\_Params Content Description

Tag Name	Content Description	Unit	Type	Size (XML)
L2B_Input_Screening_Params	Parameters used for screening the L2B input data. See Table 139 for the structure definition.		Structure	0 7257 0
Spare or whitespace				0 2240 0
<b>Total size for XML L2C AuxPar L2C Screening Params in bytes:</b>				<b>9497</b>

- end of table -

Table 139: L2B\_Input\_Screening\_Params Content Description

Tag Name	Content Description	Unit	Type	Size (XML)
L2B_Mie_Obs_Screening_Params	Parameters used for screening the L2B Mie observations from the L2B input data. See Table 140 for the structure definition.		Structure	0 2327 0
L2B_Rayleigh_Obs_Screening_Params	Parameters used for screening the L2B Rayleigh Observations from the L2B input data. See Table 141 for the structure definition.		Structure	0 2245 0
Spare or whitespace				0 2685 0
<b>Total size for XML L2C AuxPar L2B Input Screening Params in bytes:</b>				<b>7257</b>

- end of table -

Table 140: L2B\_Mie\_Obs\_Screening\_Params Content Description

Tag Name	Content Description	Unit	Type	Size (XML)
L2B_Scattering_Ratio_Min	Minimum allowed value for Scattering_Ratio_Mie (see element 2 in table 21 of section 5.3 of [RD1])		FAdoxy	0 64 0
L2B_Scattering_Ratio_Max	Maximum allowed value for Scattering_Ratio_Mie (see element 2 in table 21 of section 5.3 of [RD1])		FAdoxy	0 64 0
L2B_Mie_SNR_Threshold	Threshold on the value of Mie.Signal_to_Noise_Ratio (see element 3 in table 21 of section 5.3 of [RD1])	unitless	FAdoxy	0 58 0
Mie_Ground_Bin_Thickness_Threshold	Threshold on the part of the ground bin that is above the surface according to the DEM.	m	FAdo40	0 80 0
Max_Signal_Derivative	Threshold on the Mie spectrum to be able to detect corrupt channels	PixelLevel	IntAs	0 54 0
Pixel_Saturation_Threshold	Threshold on the Mie spectral channels to be able to detect saturated channels	PixelLevel	IntAs	0 54 0
Spare or whitespace				0 1953 0
<b>Total size for XML L2C AuxPar L2B Mie Obs. Scr. Params in bytes:</b>				<b>2327</b>

- end of table -

Table 141: L2B\_Rayleigh\_Obs\_Screening\_Params Content Description

Tag Name	Content Description	Unit	Type	Size (XML)
L2B_Rayleigh_-SNR_Min	Minimum allowed value for Rayleigh_Signal_to_Noise_Ratio_Channel_A and Rayleigh_Signal_to_Noise_Ratio_Channel_B (see elements 2 and 3 in table 25 of section 5.3 of [RD1])	unitless	FAdoxy	0 56 0
L2B_Rayleigh_-SNR_Max	Maximum allowed value for Rayleigh_Signal_to_Noise_Ratio_Channel_A and Rayleigh_Signal_to_Noise_Ratio_Channel_B (see elements 2 and 3 in table 25 of section 5.3 of [RD1])	unitless	FAdoxy	0 56 0
Rayleigh_Ground_-Bin_Thickness_-Threshold	Threshold on the part of the ground bin that is above the surface according to the DEM.	m	FAdo40	0 90 0
Pixel_Saturation_-Threshold	Threshold on the Rayleigh channels to be able to detect saturated signals	PixelLevel	IntAs	0 64 0
Spare or whitespace				0 1979 0
<b>Total size for XML L2C AuxPar L2B Rayl. Obs. Scr. Params in bytes:</b>				<b>2245</b>

- end of table -

## 5.7 Auxiliary Calibration Coefficients Dataset

Auxiliary Calibration Coefficient data are contained in the AUX\_CAL\_L2 data product. The tables are to be generated by TBD. The format for these data are defined in Section 4.3 of [RD10]. They contain instrument calibration coefficients for used in L2A processing, to account for Mie and Rayleigh channel cross-talk, or to retrieve atmospheric optical properties. They are potentially used for similar purposes within L2B processing.

- end of document -